

**Appendix F: Hazardous Waste Management
Plan
*Revised***



HAMLET OF PAULATUK

Waste Management Plan

Final

Table of Contents

1.0	Introduction	1
1.1	Contact Information.....	1
1.2	Purpose and Scope.....	2
1.3	Project Description.....	3
1.4	Site Description	3
1.5	Identification of Waste Types	3
2.0	Management of Each Waste Type	5
2.1	Waste Batteries.....	7
2.2	Used Oil and Waste Fuel	8
2.2.1	Waste Fuel	8
2.2.2	Waste Oils and Fluids.....	9
2.3	Brake Fluid	10
2.4	Waste Solvents.....	11
2.5	Antifreeze.....	11
2.6	Windshield Washer Fluid	12
2.7	Paint	13
2.8	Mercury Thermometers and Switches	13
2.8.1	Mercury Switches – Appliances	13
2.8.2	Mercury Switches – Vehicles	14
2.9	Lead.....	15
2.10	Capacitors and Ballasts	15
2.10.1	Ballasts	16
2.10.2	Capacitors	18
2.11	Propane Tanks.....	19
2.12	Ozone Depleting Substances	20
2.12.1	Refrigerants – Appliances	20
2.12.2	Refrigerants – Vehicles	21

Tables

Table 1: Contact Information and Staff Responsible for Hazardous Waste Management	1
Table 2: Hazardous Materials Storage	4
Table 3: Waste Management Methods.....	5

Figures

Figure 1: Municipal Boundaries of the Hamlet of Paulatuk	2
Figure 2: Example of Gasoline Collection System	2
Figure 3: Using Pans to Catch Draining Fluids	2
Figure 4: Using Hand Pump	3
Figure 5: Assorted Mercury Freezer Switches for Disposal.....	3
Figure 6: Chest Freezer Light with an Inline Mercury Switch (Glass Ampule).....	4
Figure 7: Washing Machine Mercury Switch.....	4
Figure 8: Gas Safety Valve Control, Gas Safety Valve Capillary Tube and Safety Valve Sensor Bulb from Gas Range.....	4
Figure 9: Sump Pump Float Containing Mercury	5
Figure 10: Example of Removing Light Assembly Containing a Mercury Switch	5
Figure 11: Mercury Pellet from Vehicle Convenience Light Stockpiling.....	6
Figure 12: Fluorescent Lamp Unit with Exposed Lamp Ballasts.....	6
Figure 13: Refrigerant Evacuation Unit	7

Appendices

A	GNWT ENR Brochure for Household Hazardous Wastes
B	Hazardous Waste Site Record
C	Paulatuk Waste Shipment Correspondence
D	Household Mercury Switch Manual
E	PCB Regulations

1.0

Introduction

This hazardous waste management plan applies to the water treatment plant, sewage lagoon and solid waste disposal facilities currently in operation within the municipal boundaries of the Hamlet of Paulatuk (the Hamlet), under water licence #N7L3-1619. The hazardous waste management plan was developed for these facilities as required for a water licence application for the Hamlet.

Under the *Waters Act (WA)* and Section 5(2) (g) of the Waters Regulation (WR), licence applications must include “where the undertaking involves the handling or storage of petroleum products or hazardous materials, (i) a plan for the safe handling, storage and disposal thereof, and (ii) a contingency plan for their containment and for the clean-up thereof in the event of a spill”.

This spill contingency plan is based on the Inuvialuit Water Board’s Spill Contingency Plan Template and the Water Resources Division Indian and Northern Affairs Canada document titled, “Guidelines for Spill Contingency Planning” (2007). Both documents can be found on the Inuvialuit Water Board’s website.

1.1

Contact Information

This Hazardous Waste Management Plan provides for the prompt and coordinated response of the Hamlet of Paulatuk, NT located 69°21’ N latitude and 124°04’ W longitude. Contacts for the Hamlet are listed in **Table 1**.

Hamlet of Paulatuk
Box 98
Paulatuk, NT
X0E 1N0
Phone: 867-580-3531
Fax: 867-580-3703
Email: hopaulatuk@gmail.com

Table 1: Contact Information and Staff Responsible for Hazardous Waste Management

Name	Role	Phone
John Holland	Senior Administrative Officer	867-580-3531
Keith Dodge	Hamlet Foreman (trained in Workplace Hazardous Materials Information Systems, Waste Management, First Aid and CPR)	867-580-3039



Figure 1: Municipal Boundaries of the Hamlet of Paulatuk

**Image retrieved from the Department of Municipal and Community Affairs, GNWT, July 2015*

1.2 Purpose and Scope

The purpose of this plan is to outline response actions for hazardous waste management. The plan identifies key response personnel and their roles and responsibilities for the management of hazardous waste. The plan has been prepared with the intent to help provide quick access to information required in responding to hazardous waste management.

1.3 Project Description

The Hamlet operates under a Type B water licence (N7L3-1619) for: the extraction of water from New Water Lake, the disposal of sewage at a local facility, and the disposal of solid waste within a landfill facility.

1.4 Site Description

The Hamlet is located on the south end of Darnley Bay in the Northwest Territories (**Figure 1**). The population of the Hamlet in 2016 was 327 based on data from the NWT Bureau of Statistics (2016). The areas pertaining to this spill contingency plan are the sewage disposal facilities and the solid waste disposal facilities (**Figure 1**). The drinking water source for the Hamlet is New Water Lake, which is located approximately 2.2 km from the community and approximately 2.3 km from the sewage and solid waste disposal facilities (**Figure 1**).

The sewage lagoon facility is a natural lake located approximately 2 km from the community. The lagoon has a natural outflow through with a vegetated corridor that is approximately 300 m long and empties into Darnley Bay.

The Hamlet's solid waste disposal site is located adjacent to the sewage lagoon approximately 2 km from the community and approximately 2.3 km west of New Water Lake (i.e., Hamlet's drinking water supply). The facility includes a municipal solid waste disposal area, a bulky waste disposal area, and a disposal area for the local Northern Store. The facility is located approximately 500 m from Darnley Bay.

Hazardous wastes, with the exception of paint, lead-acid batteries and fluid drained vehicles, are disposed and temporarily stored in a GNWT issued storage container that is locked and located at the community maintenance garage (**Figure 1**). Community members must dispose of hazardous goods through approval from hamlet foreman. Items are segregated at Solid Waste Facility or the temporary Hazardous Waste storage container and stored until shipped off to an approved facility. Hamlet foreman ensures proper sorting and storage all hazardous goods. There are no tipping fees associated with household hazardous waste.

1.5 Identification of Waste Types

The hazardous materials listed within this section are related to materials stored at the sewage lagoon facility and the solid waste disposal facility within the Hamlet of Paulatuk. Hazardous materials disposed of at the solid waste facility are currently stored within the maintenance garage located off-site within the community. **Table 2** details the storage container and stored quantities of hazardous materials. **Appendix B** details immediately reportable spill quantities.

Table 2: Hazardous Materials Storage

Material	Storage container	Average on-site*	Maximum on-site
Waste oils	45 gallon barrel	5	Until shipped off-site
Batteries (lead-acid)	Pallet	4 pallets full	Until shipped off-site
Fluids/solvents/waste liquids	45 gallon barrel	10	Until shipped off-site
Waste oils	45 gallon barrel	6	Until shipped off-site
Propane Tanks	90 pound canisters	8	Until shipped off-site
Mercury containing products (e.g., thermostats, fluorescent lights etc.)	Heavy plastic container	5**	Until shipped off-site
Raw Sewage	Sewage Lagoon	128,000 m ³	Until shipped off-site
Sodium Hypochlorite (12%)	4 litre container	180 litres	Until shipped off-site
Sodium Hydroxide	20 litre container	40 litres	Until shipped off-site
Citric Acid	20 litre container	40 litres	Until shipped off-site

*Quantities are subject to change depending on the quantities disposed of at the solid waste facility.

**Estimated average as there are no actual volumes available.

At the solid waste facility, hazardous wastes due to the disposal of vehicles and/or indiscriminate waste disposal by community residents may also be present. Empty propane tanks that are collected are stored at the solid waste facility (bulk waste site) and not at the maintenance garage. These propane tanks may contain residual propane.

The Department of Environment and Natural Resources (ENR) handles the final disposal of mercury containing products at no cost other than shipping.

The Material Safety Data Sheets (MSDS) for hazardous materials are kept at the maintenance garage, updated as required and available for reference. Current MSDS sheet are attached to the Spill Contingency Plan. As new products are acquired, new MSDS sheets are to be added to the Spill Contingency Plan. This section is to be updated regularly by the Hamlet Foreman. To ensure that the correct MSDS is being used, the MSDS provided by the manufacturer for the specific product in question must be used. Therefore, the MSDS must be updated regularly as products are purchased for use by Hamlet staff. Information contained within MSDS may also be updated therefore, every time a product is purchased, the MSDS should be requested and kept accessible in the Hamlet's maintenance garage.

2.0

Management of Each Waste Type

Hazardous wastes include waste such as: paint, waste oil, waste fuel, mercury thermometers and switches from household appliances, capacitors and ballasts, antifreeze, propane tanks, small flammable or explosive containers, etc (**Appendix A**). These items should be stored within a marked and separate area located at the solid waste site, until the wastes can be properly crated and shipped to an appropriate disposal facility (**Appendix C**). It is imperative that these wastes be kept separate from each other and that **NO** mixing of these materials is to occur.

Hamlet foreman is responsible for segregating and depositing household hazardous waste materials into the designated areas. Foreman must be properly trained to follow safe hazardous waste segregation procedures. Any hazardous materials not stored in the proper area must be removed and placed in the appropriate storage area by Hamlet appropriate staff. Hamlet staff will also be responsible for properly crating hazardous material for shipment. Hamlet foreman must supervise hazardous waste handling and ensure MSDS sheets are referenced.

Only properly trained personnel should handle hazardous materials. Please contact the Workers' Safety Compensation Commission (toll free: 1-800-661-0792) for further information on obtaining proper training and certification to handle such materials.

A description of the activities involved in the management of project waste from generation to disposal and the rationale for the methods employed are provided in **Table 3**. There is a hazardous waste area present in the Paulatuk landfill where materials such as paint, household hazardous waste and old fuel drums are disposed. Waste oil generated by the Hamlet is stored in sealed drums until they can be transported out of the community on a barge.

Table 3: Waste Management Methods

Waste Type	Management Activities	Rationale
Waste oils	To be placed into a drum and be disposed of at landfill site.	Will have to be stored at the landfill until wastes can be shipped off-site. Fly in/out community. Will need barge to remove waste from site.
Batteries (Lead-acid)	To be placed in the hazardous waste area of the landfill.	Will have to be stored at the landfill until wastes can be shipped off-site. Fly in/out community. Will need barge to remove waste from site.

Fluids/solvents/waste liquids	To be placed into a drum and be disposed of at landfill site.	Will have to be stored at the landfill until wastes can be shipped off-site. Fly in/out community. Will need barge to remove waste from site.
Propane Tanks	To be placed in the hazardous waste area of the landfill.	Will have to be stored at the landfill until wastes can be shipped off-site. Fly in/out community. Will need barge to remove waste from site.
Mercury containing products (e.g., thermostats, fluorescent lights etc.)	To be placed in the hazardous waste area of the landfill.	Will have to be stored at the landfill until wastes can be shipped off-site. Fly in/out community. Will need barge to remove waste from site.
Raw Sewage	Disposed of in the sewage lagoon.	All sewage from the community is disposed of in the sewage lagoon.
Sodium Hypochlorite (12%)	To be placed into a drum and be disposed of at landfill site.	Will have to be stored at the landfill until wastes can be shipped off-site. Fly in/out community. Will need barge to remove waste from site.
Sodium Hydroxide	To be placed into a drum and be disposed of at landfill site.	Will have to be stored at the landfill until wastes can be shipped off-site. Fly in/out community. Will need barge to remove waste from site.
Citric Acid	To be placed into a drum and be disposed of at landfill site.	Will have to be stored at the landfill until wastes can be shipped off-site. Fly in/out community. Will need barge to remove waste from site.

Daily inspections of the Hazardous Waste Containment areas and Temporary Hazardous Storage containers are carried out and records are maintained in a file at the garage. Weekly inspections of hazardous materials are completed by site foreman and stored at the hamlet garage. A sample of the log can be found in **Appendix B**.

2.1

Waste Batteries

Collection

Waste batteries include vehicle batteries from cars, trucks, snowmobiles, etc. A vehicle's battery should be removed first in order to de-energize the ELV. This will allow for safer removal of all other materials from the vehicle. Waste batteries from ELVs contain corrosive fluids and heavy metals that may contaminate the environment if not stored and disposed of properly (Department of Sustainable Development, Government of Nunavut, 2002). Therefore all waste batteries from ELVs must be removed during the dismantling process.

Stockpiling

Waste batteries should be stored in a leak-proof drum (metal or plastic) with a secured lid to protect batteries from rain and snow. Batteries may be stacked, but a layer of cardboard or plywood must be placed between the layers of batteries. If batteries are stacked without cardboard or plywood between the layers, there is the potential for the batteries to short and cause an electrical fire. The batteries must be secured to the pallets by nylon straps and must not be stacked more than two batteries high. A polyethylene containment liner must be used and must be large enough to place under the batteries and then wrap around them to create a sealed containment unit (Department of Sustainable Development, Government of Nunavut, 2002).

Disposal

Waste batteries may be sent to recycling facilities in southern Canada. The solid waste site operator will have to contact a recycling/disposal facility and make arrangements for that facility to receive the waste batteries. Please contact the appropriate transport authority (marine, rail, road) for appropriate shipping and transportation instructions of waste batteries. Proper packaging and labels will be required prior to transport out of the Hamlet.

The site operator should contact the Transportation of Dangerous Goods Northern Regional Office at 1-888-463-0521 to ensure that the batteries are properly crated and have the appropriate labels prior to shipping. Ensure that manifests and transportation records are kept onsite.

Please refer to the *Guideline for Management of Waste Batteries* found on the Environmental and Natural Resources, Government of Northwest Territories website for further instructions on the collection, storage and disposal of waste batteries:

<http://www.enr.gov.nt.ca/sites/enr/files/guidelines/batteryguideline.pdf>¹.

¹ Last accessed September 1, 2017

2.2 Used Oil and Waste Fuel

According to the *Used Oil and Waste Fuel Regulations Plain Language Guide* (Department of Environment and Natural Resources, Government of Northwest Territories, 2003) used oil is defined as “any heavy, hydrocarbon-based lubricating oil that has become unsuitable for its original purpose”. Examples of used oil include: crankcase oil, hydraulic fluid, automatic transmission fluid and gear oil (Department of Environment and Natural Resources, Government of Northwest Territories, 2003). In the same document, waste fuel is defined as “flammable or combustible hydrocarbon that has become unsuitable for its original purpose”. Examples of waste fuel include: gasoline, diesel fuel, furnace fuel, aviation fuel, kerosene and naphtha (Department of Environment and Natural Resources, Government of Northwest Territories, 2003).

As waste fuels and waste oils are different substances, each requires separate and specific disposal techniques. The following paragraphs describe the collection, storage and disposal options for both waste fuels and waste oils.

2.2.1 Waste Fuel

Collection

Waste fuel pertains to fuels such as gasoline and diesel. These fuels should be collected and stored separately in dedicated containers (**Figure 2**). Do not mix gasoline and diesel. Fuels that are still usable (i.e., gasoline that has not gone stale) may be used in onsite vehicles. Stale gasoline cannot be used in vehicles as it may cause damage and must be handled and disposed of as a hazardous waste (British Columbia Ministry of Environment, 2008). Stale gasoline can often be identified by a bad smell caused by degradation of the fuel.

Gasoline can be dangerous as it is flammable and may catch on fire or explode if it comes into contact with a spark or ignition source. Gas should be removed in a well-ventilated area and stored outside of the dismantling area. Remove gas using a suction system specifically designed for the removal of gasoline. Do not use a plastic hand pump as this may cause a build-up of static electrical charge and may lead to fire or explosion. Do not puncture holes in a tank to drain gasoline or diesel; this may result in leaks or spills (National Code of Practice, 2008; British Columbia Ministry of Environment, 2008).

Stockpiling

Usable fuel may be stored in storage containers approved for the specified type of fuel and reused in onsite vehicles. These containers must be kept in a well-ventilated area outside of the dismantling area to prohibit fume build-up and decrease the risk of fire. Stale gasoline and waste fuel must also be stored in approved containers in a well-ventilated area outside of the dismantling area and must be labelled as waste/unusable fuels. Secondary containment should be provided. If stored outdoors, these containers should be protected from rain and snow. Contact the Fire Marshal for approval of fuel and waste fuel storage locations.

Disposal

Usable fuel should be reused where possible to decrease the amount of waste fuels to be transported offsite. This will decrease shipping and disposal costs. Waste fuels and stale gasoline must be collected and transported offsite. These fuels will need to be transported offsite by a licensed Transportation of Dangerous Goods shipper. Arrangements will have to be made with the shipping company to complete the appropriate manifests and have the approved packaging for transportation offsite. Records of manifests must be kept onsite for a minimum of two years.

2.2.2 Waste Oils and Fluids**Collection**

Waste oils found in ELVs include: engine oil; transmission, power steering, and brake fluids; and differential oil. According to the National Code of Practice (2008), brake, transmission and power steering fluids may be mixed with waste oil. However, based on information from Yukon Environment (2005) and Missouri Department of Natural Resources (1997) due to chlorinated compounds that may be found in some brake fluids, it is recommended that brake fluid not be mixed with waste oils.

It is recommended that brake fluid be collected with a dedicated pump and stored separately from other oils. Other oils i.e., engine, transmission, power steering and differential can be collected using a common pump and stored in a mixed oil container. Brake fluid should be tested when the brake fluid storage container is full to determine chlorinated content and end disposal.

Waste oils can be collected by draining from the vehicle components or by using a hand pump. When draining, use a drip pan to collect the fluids (**Figure 3**). Once all the fluid has been drained from the component, replace the drain plug, empty the fluid into the designated and marked storage container. For differentials, replace all removed bolts to prevent leakage.

When using a hand pump to remove fluids, ensure that each fluid (aside from oils such as engine, transmission, power steering and differential) has a dedicated hand pump (**Figure 4**). Do not use the same hand pumps for brake fluid, antifreeze, windshield washer fluid, etc. Once all fluid has been drained, empty the container of each pump directly into the designated storage container.

Stockpiling

Waste oil may be stored in steel drums or plastic containers. Both types of containers must have proper fitting lids. These containers may be kept in the dismantling area within a secondary containment unit. According to the British Columbia Ministry of Environment (2008), steel drums on spill pallets are recommended over plastic containers as plastic tends to degrade over time and could potentially cause a leak or spill.

Disposal

Waste oil can be disposed of in different ways, however the most appropriate disposal methods for the Northwest Territories include transportation to a recycling facility or used as fuel in a waste oil furnace. Transporting to a recycling facility will involve shipping waste oil out of the community via barge or plane. Hazardous waste/recyclable manifests will need to be completed.

Use of waste oil as a fuel in an approved furnace will eliminate the need to ship waste oil to a southern recycling facility. However, before burning waste oil, the composition of the waste oil must be known (i.e., what type of waste oil is it, what other waste oils or waste fluids are mixed in with the waste oil) and it must be determined that the waste oil is safe for use in an approved waste oil furnace. In the event that a waste oil furnace is not available, some waste oils may be burned on-site in an approved incinerator. This task would involve contracting out to a contractor trained in burning and disposing of waste oils. The contractor must be knowledgeable about what types of waste oils may be burned in the incinerator. The contractor would bring in an approved incinerator to Paulatuk and burn the waste oils appropriate for burning on-site. Any unknown waste oils or fuels will have to be tested by an approved laboratory to determine their composition prior to incineration or shipment out of the Hamlet. Other waste oils not suitable for use in a waste oil furnace or burning in the incinerator will be properly packaged for shipment to an approved disposal facility. The site operator should contact the Transportation of Dangerous Goods Northern Regional Office at 1-888-463-0521 to ensure that all waste oils are properly crated and have the appropriate labels prior to shipping. Waste must only be transported to an approved user/recycler of waste oil.

All barrels containing waste oils or fuels and all barrels that have not been properly cleaned must be stored in a designated area at the solid waste site.

For further information refer to the *Used Oil and Waste Fuel Regulations Plain Language Guide* located on the Department of Environment and Natural Resources, Government of Northwest Territories website at: http://www.enr.gov.nt.ca/sites/enr/files/guidelines/used_oil_guide.pdf.²

2.3 Brake Fluid

Collection

Brake fluid may be collected using a hand pump as described for the collection of waste oils. The fluid should then be disposed of into a container designated specifically for brake fluid.

Depending on the end disposal methods of the collected waste oil, brake fluid should not be mixed with waste oil as it may contain chlorinated compounds. Chlorinated compounds when burned in a waste oil burner may cause smoke, fumes or problems with the waste oil burner (Yukon Environment, 2005 and

² Last accessed September 1, 2017

Missouri Department of Natural Resources, 1997). According to the Missouri Department of Natural Resources (1997), brake fluids may contain chlorinated compounds if:

- An older brake fluid manufactured using chlorinated compounds was used; or
- It had become contaminated from brake cleaners that contain chlorinated compounds.

To be sure, the solid waste facility operator may want to use a test kit to determine whether or not the used brake fluid contains chlorinated compounds. The facility operator will have to contact the waste oil recycler/disposal company to determine if they will accept waste oil mixed with brake fluid that may contain chlorinated compounds (Missouri Department of Natural Resources, 1997).

Stockpiling

Brake fluid may be stockpiled in approved clearly labelled containers until it can be shipped out by barge. Waste brake fluid should be kept separate from other waste oils unless the solid waste facility operator has contacted the recycling/disposal company and has confirmed with them that adding brake fluid to the waste oil is acceptable.

Disposal

Waste brake fluid must be shipped out of the community by annual barge by a licensed Transportation of Dangerous Goods shipper. Brake fluid must be sent to a proper disposal/recycling facility and arrangements with the facility to accept brake fluid must be made prior to shipping.

2.4 Waste Solvents

Waste solvents are liquids that are generally derived from petroleum or alcohol based products and may be flammable or toxic (Environmental Protection Service, Department of Sustainable Development, Government of Nunavut, 2002). They must be handled only by properly trained personnel. For further information please refer to the *Guideline for the Management of Waste Solvents* located on the ENR Government of Northwest Territories website at:

<http://www.enr.gov.nt.ca/sites/enr/files/guidelines/solvents.pdf>.³

2.5 Antifreeze

Antifreeze is a liquid used to lower the freezing point of water. It must be handled and stored with care as it is a toxic compound.

Collection

Antifreeze may be collected by using a hand pump to remove it from the ELV. It must be stored in a clearly marked steel drum or plastic container and must not be mixed with other waste fluids such as oils, windshield washer fluid, brake fluid, etc. Water contaminated by antifreeze must not be put through an oil/water separator as a method of treatment. Oil/water separators do not remove antifreeze from water

³ Last accessed September 1, 2017

and if discharged through an oil/water separator the antifreeze may be released into the environment (British Columbia Ministry of Environment, 2008).

Stockpiling

Waste antifreeze must be stored in an appropriate container with a secure lid. Containers should be stored within a secondary containment area that does not have a drain, thereby preventing the release of antifreeze into the environment. Antifreeze that is reusable can be used within other operating vehicles (British Columbia Ministry of Environment, 2008). Unusable antifreeze must be kept separate and stored until it can be shipped out of the community.

Disposal

Antifreeze must not be disposed into the environment as it is toxic to humans and animals and may contaminate the soil and water. It must be stockpiled until it can be shipped to a proper disposal facility. Transportation and manifest records of shipments of waste antifreeze must be kept onsite for a minimum of two years (British Columbia Ministry of Environment, 2008).

Antifreeze must not be disposed of in sewage lagoons as it may kill the bacteria responsible for the sewage treatment process (Environmental Protection Service, Department of Sustainable Development, Government of Nunavut, 2002). For further information please refer to the Guidelines for Management of Waste Antifreeze located on the Environment and Natural Resources, Government of Northwest Territories website at: <http://www.enr.gov.nt.ca/sites/enr/files/guidelines/antifreezeguideline.pdf>.⁴

2.6 Windshield Washer Fluid

Collection

Windshield washer fluid is a toxic substance that must be drained from all ELVs prior to crushing. Remove washer fluid from ELVs by using a dedicated hand pump and draining the fluid into a dedicated container. Do not mix with other fluids such as engine oil, antifreeze, brake fluid, transmission fluid, etc. Sell or give away reusable washer fluid for use in other operational vehicles.

Stockpiling

Washer fluid must be stored in an appropriate container with a secure lid. Containers should be stored within a secondary containment, area that does not have a drain in order to prevent the release of washer fluid into the environment. Most washer fluid is reusable and can be used within other operating vehicles (British Columbia Ministry of Environment, 2008). Unusable washer fluid must kept separate and stored until it can be shipped out of the community.

⁴ Last accessed September 1, 2017

Disposal

Waste washer fluid must not be disposed into the environment as it is a toxic substance. It must be stockpiled until it can be shipped to a proper disposal facility. Transportation and manifest records of shipments of waste fluid must be kept onsite for a minimum of two years.

2.7 Paint

Waste paint and paint products may be considered hazardous materials depending on the chemical properties of the paint and products (Environmental Protection Service, Department of Sustainable Development, Government of Nunavut, 2002). Waste paint and paint products should be stored in designated hazardous waste storage berms away from other hazardous wastes. For further information refer to the *Guidelines for the Management of Waste Paint* located on the Environment and Natural Resources, Government of Northwest Territories website at:

<http://www.enr.gov.nt.ca/sites/enr/files/guidelines/paintguideline.pdf>.⁵

2.8 Mercury Thermometers and Switches

There are two main sources of mercury that may be found in a municipal solid waste site, mercury switches found in appliances and mercury switches found in ELVs. Mercury is a toxic heavy metal that is used in vehicles and a number of household items such as freezers, washing machines, gas ranges, gas hot-water heaters, fluorescent lamps, etc. When these items are disposed of in a landfill, mercury may be released into the environment due to crushing of these items (Vermont Department of Environmental Conservation, Vermont Mercury Education & Reduction Campaign and Chittenden Solid Waste District, 2002). It is important that the parts of these appliances that contain mercury be removed prior to disposal in the solid waste site. The following paragraphs describe collection, storage and disposal for mercury found in both appliances and ELVs.

2.8.1 Mercury Switches – Appliances**Collection**

Mercury switches may be found in a variety of appliances, generally those that have automatic shut-off features and/or convenience lighting. These appliances may include freezers, washing machines, gas ranges, gas hot water heaters, gas furnaces, sump pumps, etc. However, caution must be taken when identifying and retrieving switches from appliances. See **Figure 5** to **Figure 9** for examples of mercury containing switches from household products. The Vermont Department of Environmental Conservation in conjunction with the Vermont Mercury Education & Reduction Campaign and Chittenden Solid Waste District have developed a manual titled *Household Appliance Mercury Switch Removal Manual*. A copy of this manual has been included as **Appendix D** and can be found on the following website:

<https://anrweb.vt.gov/dec/mercury/PDF/appman.pdf>.⁶

⁵ Last accessed September 1, 2017

⁶ Last accessed September 1, 2017

Stockpiling

Once mercury containing units have been removed, they should be stored in a heavy plastic container with a proper fitting lid. Containers must be in good condition and must not leak. It is advisable not to use an aluminum or tin container as mercury may react with these metals and may leak through the container. Container contents must be marked on the outside of the container and containers must be stored in a dry location where they will not be disturbed (California Environmental Protection Agency, 2005).

Disposal

Scout Environmental operates the Mercury Switch Out Program for ELVs in conjunction with the Canadian Appliance Manufacturers Association, and is currently working on developing a similar program for the collection and disposal of mercury switches from appliances. Information regarding this program can be found on the following website: <http://www.switchout.ca/index.aspx>.⁷

2.8.2

Mercury Switches – Vehicles

Collection

The Mercury Switch Out Program is a program that was developed to help automotive recyclers and dismantlers remove and dispose of mercury switches safely from ELVs. When an ELV dismantling facility registers with the program, Scout Environmental staff will send to the facility training and educational materials, a collection container for the mercury switches and a pre-paid waybill to send the container back once it is full.

All mercury switches must be removed from ELVs prior to crushing the vehicle hulks. Mercury switches can be found in trunks, hoods, convenience lighting and anti-lock braking systems. Not all vehicles have the same number of mercury switches and not all switches are found in the same locations in each vehicle. The Mercury Switch Out Program website has a number of resources to help ELV facility operators locate mercury switches in various vehicle models and step by step instructions on how to remove these switches. For each convenience light location, the following general steps must be taken (**Figure 10**):

1. Locate the lighting assembly under the vehicle trunk and/or hood;
2. Remove any fasteners to separate the entire lighting assembly from the vehicle;
3. Break open the lighting assembly to expose the mercury switch capsule (a sealed metal pellet). Small flathead screwdrivers and wire cutters are often the only tools that are required; and
4. Remove the mercury switch capsule (using a small screwdriver) and place it in the *Switch Out* collection container (**Figure 11**). Replace the lid on the container. The remaining plastic/metal from the lighting assembly can be disposed of with regular waste. If the mercury switch capsule cannot be removed from the assembly, place the entire assembly in the Switch Out collection container.

⁷ Last accessed September 1, 2017

On vehicles with ABS breaking systems, the following general steps must be taken:

1. Locate the ABS G-Force sensor module on the vehicle. Module locations include: the drive tunnel, below the rear seat on the floor pan, on the right front wheel apron, and on the left frame rail right below the driver; and
2. Remove the ABS G-Force sensor module and place the entire sensor module in the *Switch Out* collection container. Replace the lid on the container. **Note:** The ABS G-Force sensor module contains either two or three mercury switch capsules embedded in the casing. **Do not** attempt to remove the mercury switch capsules from the sensor module.

Most of the mercury found in these switches is contained within a metal capsule and therefore the likelihood of a spill is relatively low. However, should a metal capsule break, refer to the Switch Out Clean-Up Instructions located on the Mercury Switch Out Program's website for proper techniques to clean up the spill.

2.9

Lead

Collection

Most lead in ELVs comes from wheel weights and battery cable ends. These items must be removed from vehicles prior to crushing and stored in separate, covered strong containers. Lead can be recycled into other usable items (National Code of Practice, 2008 and British Columbia Ministry of Environment, 2008).

Stockpiling

Store lead wheel weights and battery cable ends in separate, covered strong metal or wooden containers.

Disposal

Lead can be recycled into other usable items. The ELV operator will have to contact a metals recycler and make arrangements for them to accept the recovered lead.

2.10

Capacitors and Ballasts

Capacitors are commonly found in electronic devices, appliances and power supply equipment. Ballasts for disposal are most commonly associated with fluorescent light fixtures. All capacitors and ballasts found in electronic devices, appliances and light fixtures must be removed prior to landfilling these items.

Removal of capacitors and ballasts found in construction/demolition projects are generally completed by contractors. Prior to 1980, capacitors and ballasts contained PCBs (PCB Disposal, 2008) which is a chemical that may have adverse effects on human health (Health Canada, 2005). The Hamlet should not accept these wastes from construction sites as it is the responsibility of the contractor to properly dispose of capacitors and ballasts. If a site operator observes such items or suspects that items within the solid waste facilities may contain capacitors or ballasts, contact the Department of Environment and Natural Resources, Government of Northwest Territories at (867) 767-9055 ext. 53001.

As for capacitors and ballasts contained in waste appliances, these items should be removed prior to landfilling and/or sending south for recycling. Southern recyclers will most likely require that all capacitors and ballasts are removed from these items prior to accepting them at their facilities. Ballasts and capacitors may be found in lights, starters in motors, starters in fridges and stoves, etc. However, if the Hamlet will be removing these items, the solid waste facility will need to register as a waste generator with the Government of Northwest Territories, Environment and Natural Resources.

Ballasts and capacitors should be stored in separate 45 gallon drums, kept in a secured location and protected from the weather. Workers removing these items should wear standard personal protective equipment including goggles and acid resistant gloves as an asphalt type paste may leak from these items. Further information specific to ballasts and capacitors can be found in the following paragraphs.

2.10.1

Ballasts

Collection

Ballasts are components generally found in fluorescent lighting fixtures and high intensity discharge (HID) lamps. In fluorescent lighting fixtures, the ballasts are usually found between two fluorescent tubes and protected by a heat shield (**Figure 12**). HID ballasts are generally found encased within a box attached to the outside of the light fixture or located within the light housing. Examples of HID lamps include streetlights and parking garage lights (Environment Canada, 1991).

It should be noted that fluorescent lights found in appliances such as stoves may contain ballasts that may have PCB material within them. Unless ballasts are identified as “PCB free”, these items should be removed and properly disposed of as hazardous waste.

Fluorescent ballasts contain a core/coil unit, a thermal protector and a capacitor. The capacitor may contain PCBs. It is the PCBs that are of concern as they may pose a risk to human and environmental health. These ballasts may also be filled with an asphalt/silica type compound. If the ballast contains this compound, the capacitor within the ballast will not be readily accessible. Therefore it is important that the entire ballast unit is removed and disposed of through a proper hazardous waste disposal company. HID ballasts usually require higher levels of capacitance than fluorescent ballasts. Therefore they often contain more capacitors and hence may contain more PCBs than fluorescent light ballasts (Environment Canada, 1991).

In the late 1970s to early 1980s, many companies began phasing out the use of PCBs in capacitors. However, there are still ballasts with capacitors in use today that may contain PCBs and therefore caution must be taken when removing and disposing of ballasts. In order to determine if a ballast contains PCBs, the manufacturer of the ballast should be contacted. The manufacturer should be able to determine whether the ballast contains PCBs based on the date codes and/or catalogue codes on the ballast casing (Environment Canada, 1991). Many manufacturers also began labelling non-PCB containing electrical

equipment to aid in proper handling. Equipment labelled as “PCB-free” or “Non PCB” does not require removal. The solid waste site operator should mark each appliance as inspected and cleared as appropriate.

Caution must be taken when removing ballasts. The fixture must be de-energized prior to removal of the ballast and must not be re-energized during the removal. Capacitors may also hold a charge for several days after their last use and therefore there is a risk of electric shock to persons removing capacitors. As there is a possibility of PCBs leaking from the ballast, goggles and acid resistant gloves must be worn when removing and handling the ballast (Connecticut Department of Environmental Protection, 2005).

It should be noted that fluorescent lamp tubes contain mercury phosphor powder, lead and cadmium and must not be disposed of in the general waste stream. They must be disposed of through an approved hazardous waste recycler and/or disposal company. If the tubes are not broken, they may be packaged in their original packaging and sent to an approved facility with no further special transportation requirements. However, if the tubes are broken, special safety, handling, packaging and transportation requirements must be met. Safety procedures are of utmost importance to prevent worker exposure to mercury. In the case of disposing of a broken fluorescent tube, contact a safety officer at the Prevention Services Division, Workers Compensation Board in Yellowknife at 1-800-661-0792 (Environmental Protection Service, 2003).

Stockpiling

The PCB Regulations (published in the Canada Gazette, 2008) under the Canadian Environmental Protection Act, 1999 states in paragraph 24:

“PCBs or products containing PCBs shall be stored at a site that is

- (a) a building, room, shipping container or other enclosed structure; or
- (b) an area that is enclosed by a woven mesh wire fence or any other fence or wall with similar security characteristics, and the fence or wall shall be at least 1.83 m high.”

The PCB Regulations go on to state in paragraph 25:

“The owner or operator of a PCB storage site shall

- (a) store all PCBs or products containing PCBs that are in liquid form in
 - (i) sealed containers, other than drums, that are made of steel or other metals that provide sufficient durability and strength to prevent those PCBs or products from being affected by the weather or released, or
 - (ii) drums that are
 - (A) of a capacity not greater than 205 L,
 - (B) a closed-head double-bung drum made of steel having a gauge of 16 or heavier, and
 - (C) painted or treated to prevent rusting;

- (b) store all PCBs or products containing PCBs that are in solid form in
 - (i) containers, other than drums, that are made of steel or other materials that provide sufficient durability and strength to prevent those PCBs or products from being affected by the weather or released, or
 - (ii) drums that are
 - (A) of a capacity not greater than 205 L,
 - (B) made of steel having a gauge of 18 or heavier,
 - (C) equipped with a securely attached, removable steel lid and a gasket made of material that is resistant to the PCBs or the products containing PCBs that are stored in the drums, and
 - (D) painted or treated to prevent rusting;

- (c) store equipment containing PCB liquids in
 - (i) containers, other than drums, that are made of steel or other materials that provide sufficient durability and strength to prevent the equipment from being affected by the weather and to prevent any PCB liquid that leaks from the equipment from being released, or
 - (ii) drums described in subparagraph (b)(ii);”

Paragraph 25 goes on to list the storage space requirements for the above described containers. A copy of the PCB Regulations has been included as **Appendix E** to this plan. Please refer to this document for further proper storage, handling and documentation information and requirements.

Disposal

As previously stated, ballasts containing hazardous materials must be sent to an approved hazardous waste disposal facility. PCB Disposal (a division of Sanexen Environmental Services Inc.) is a company located in Ontario that will accept and dispose of PCB containing ballasts. They have also published a document to help identify ballasts that may contain PCBs. Further information regarding this company can be found on the website at <https://sanexen.com/en/>.

2.10.2 Capacitors

Collection

Capacitors found in household appliances are predominantly labelled as either ‘oil-filled’ or ‘dry’. Oil-filled capacitors are often referred to as running capacitors. Running capacitors are generally used in applications where they are required to be in use during the entire operating time. As they are constantly in use, heat builds up within the capacitor. The oil contained within the capacitor helps to dissipate this heat. Oil-filled capacitors manufactured prior to the late 1970s and early 1980s may contain PCB compounds within the oil. In order to determine if the capacitor contains PCB material, contact the manufacturer and provide the date and/or catalogue code located on the capacitor casing. Some capacitors may be stamped with “NO PCBs” on the casing. In this case, the capacitor does not contain

PCBs. Appliances that most likely contain oil-filled capacitors include air conditioners, copy machines, microwave ovens, mercury vapour lamps, dehumidifiers and submersible well pumps. Capacitors in microwaves can be found behind the front control panel and wired to the transformer (Connecticut Department of Environmental Protection, 2005).

Be aware that oil-filled space or portable heaters may not contain a PCB capacitor, however, PCBs may be found within the actual oil. Although most oil-filled space heaters do not contain PCBs, those that do may have very high concentrations of PCBs. It is recommended that any of these types of heaters be tested for the presence of PCBs prior to crushing or disposal (Connecticut Department of Environmental Protection, 2005).

Dry capacitors are generally known as starting capacitors as they are used to start a motor during the initial start-up. Once the motor is running, they are no longer needed and so are not used during the entire motor operation. Because these capacitors are only used for short periods of time, they do not produce much heat and therefore do not require oil for heat dissipation. Starting capacitors are usually identified by a non-sealed black casing or outer shell. Starting capacitors are generally found in clothes dryers, fans, refrigerators, stoves, televisions, washing machines and various electronic devices. These capacitors are not known to contain PCB materials and so are not required to be handled as hazardous waste material.

Stockpiling

Capacitors containing PCBs should be stockpiled as outlined under the stockpiling section for ballasts as per this O&M Plan.

It is important to keep ballasts and capacitors containing PCBs away from fire hazards. Fire may cause these items to explode and release PCBs into the environment.

Disposal

Capacitors containing PCBs should be disposed of as outlined under the disposal section for ballasts as per this O&M Plan.

2.11 Propane Tanks

Most household type propane cylinders use a vapour withdrawal system that works by withdrawing the propane vapour from the top of the cylinder. The propane vapour sits above the propane liquid within the cylinder, therefore these types of propane cylinders must always be stored and transported in a vertical position. If the cylinder is on its side or upside down, liquid propane may be drawn out of the cylinder and pose an extreme danger (Nova Scotia Department of Environment and Labour, 2006). These cylinders should always be stored outside, in a vertical position (not upside down), off the ground on a non-combustible base, and away from all possible sources of heat or ignition (Propane Gas Association of

Canada, 2010). At the solid waste facilities, these cylinders should be stored outside in an open area at the hazardous waste disposal area and away from other hazardous wastes.

Some propane cylinders however are designed for horizontal use and are to be stored and transported on their side (Nova Scotia Department of Environment and Labour, 2006; Propane Gas Association of Canada, 2010). If the site operator is unsure what type of cylinder is onsite, or for further information regarding safe disposal methods of propane cylinders and tanks contact the Canadian Propane Association toll free at 1-877-784-4636.

2.12 Ozone Depleting Substances

Ozone depleting substances (i.e., refrigerants) are chemicals that when released into the atmosphere, have a negative effect on the ozone layer. These chemicals are commonly found in refrigerators, freezers, automobile air conditioning units, air conditioning equipment, etc. (Environmental Protection Service, Department of Sustainable Development, Government of Nunavut, 2002). When these items are ready to be stored at the solid waste site, all ozone depleting substances must be removed from them. Ozone depleting substances must be removed only by a certified technician (Environmental Protection Service, Department of Sustainable Development, Government of Nunavut, 2002). If a certified technician is not available, the Hamlet should contact the Environment and Natural Resources Government of the Northwest Territories to develop a plan for removal and disposal of ozone depleting substances from the solid waste site. The following paragraphs describe the collection, storage and disposal methods for refrigerants from both ELVs and appliances. For further information refer to the Environmental Guideline for Ozone Depleting Substances and Halocarbon Alternatives (Environment and Natural Resources, Government of Northwest Territories, 2007) located on the Environment and Natural Resources, Government of Northwest Territories website at:

http://www.enr.gov.nt.ca/sites/enr/files/guidelines/guideline_for_ozone_depleting_substances_and_halocarbon_alternatives.pdf.⁸

2.12.1 Refrigerants – Appliances

Refrigerants must be removed by a certified technician trained for this task. The Hamlet will hire a contractor trained in the removal of refrigerants from appliances to go to the Hamlet once per year and remove these substances from appliances stored in the bulky metals site. Prior to the contractor arriving in Paulatuk, Hamlet crews will ensure that all old appliances are all grouped in the designated white goods area. Refrigerants must not be vented into the atmosphere.

Collection

Refrigerants are found in refrigerators, freezers, window air conditioners and dehumidifiers. Removal of refrigerants must be performed only by a certified technician. Technicians must use an approved portable

⁸ Last accessed September 1, 2017

refrigerant recovery unit and follow approved procedures for removal of refrigerants from appliances. Venting of refrigerant into the atmosphere is unacceptable (Environment Canada, 2010).

Appliance dismantlers should also be aware that oil found in the appliance compressors may be contaminated with refrigerants. A certified refrigerant removal technician should be able to safely remove and dispose of refrigerants in the oil and the contaminated compressor oil (Environment Canada, 2010).

Stockpiling

Recovered refrigerant must be stored in an approved storage container for the transport of refrigerant materials. Different refrigerants should not be mixed and refrigerant containers that held one type of refrigerant should not be used to hold another type (Environment Canada, 2010). The refrigerant recovery technician must be knowledgeable of which containers are approved for the collection and transport of recovered refrigerant. Technicians must also keep a record of what type and how much refrigerant was removed. Storage containers must be labelled appropriately for transport.

Disposal

Waste refrigerant from appliances can be disposed of through the Refrigerant Management Canada™ program on a fee basis. This program was set up to safely collect and destroy refrigerant compounds without releasing them into the atmosphere. For more information on the program or for contact information on coordinating disposal of waste refrigerants please contact an RMC Collection Service Provider. Contact information for providers can be found on the Refrigerant Management Canada™ website: <http://www.refrigerantmanagement.ca/index.php>.⁹

2.12.2 Refrigerants – Vehicles

Collection

Refrigerants should be removed after the battery has been removed and prior to removal of any other fluids or items from ELVs. This is to prevent an accidental release of refrigerants into the atmosphere. Removal of refrigerants must be performed only by a certified technician. Technicians must use an approved portable refrigerant recovery unit to remove refrigerants from ELVs. They must also record the amount of refrigerant removed per vehicle. Once refrigerants have been removed, the technician must clearly label each vehicle as such (British Columbia Ministry of Environment, 2008).

Stockpiling

Refrigerants must be stored in approved, refillable storage containers (**Figure 13**) Refrigerants must not be vented to the atmosphere. Storage containers must be properly labelled and should be replaced or hydrostatically tested every five (5) years (British Columbia Ministry of Environment, 2008).

⁹ Last accessed September 1, 2017

Records of all refrigerants removed from ELVs must be maintained onsite. Records should contain the amount of refrigerant removed from each vehicle, the date it was removed, name of the certified technician who performed the recovery, registration number of the certified technician, whether the technician performed the service as an employee or agent of the business and the name of the business responsible for removal of refrigerant (British Columbia Ministry of Environment, 2008).

Disposal

Waste refrigerant from vehicles can be disposed of through the same methods as appliance refrigerants.

Figures



Figure 2: Example of Gasoline Collection System



Figure 3: Using Pans to Catch Draining Fluids



Figure 4: Using Hand Pump



Figure 5: Assorted Mercury Freezer Switches for Disposal

(Source: Vermont Department of Environmental Conservation, Vermont Mercury Education & Reduction Campaign, Chittenden Solid Waste District, 2002)



Figure 6: Chest Freezer Light with an Inline Mercury Switch (Glass Ampule)
(Source: Vermont Department of Environmental Conservation et al., 2002)



Figure 7: Washing Machine Mercury Switch
(Source: Vermont Department of Environmental Conservation et al., 2002)



Figure 8: Gas Safety Valve Control, Gas Safety Valve Capillary Tube and Safety Valve Sensor Bulb from Gas Range
(Source: Vermont Department of Environmental Conservation et al., 2002)



Figure 9: Sump Pump Float Containing Mercury

(Source: Vermont Department of Environmental Conservation et al., 2002)



Figure 10: Example of Removing Light Assembly Containing a Mercury Switch



Figure 11: Mercury Pellet from Vehicle Convenience Light Stockpiling

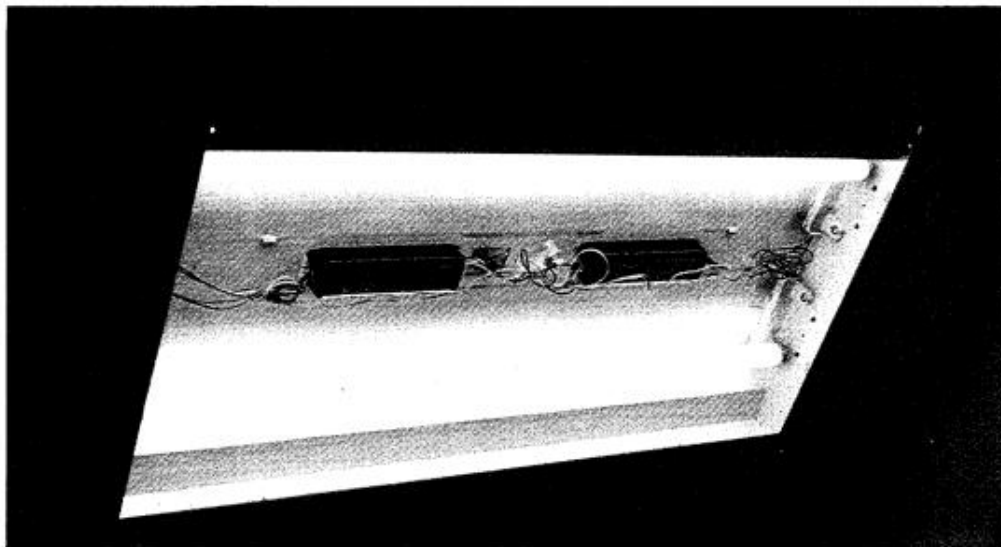


Figure 12: Fluorescent Lamp Unit with Exposed Lamp Ballasts
(Source: Environment Canada, 1991)



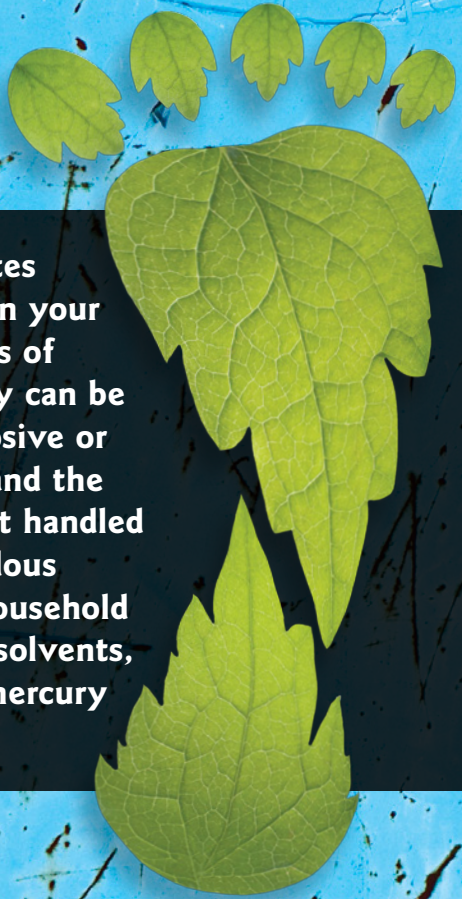
Figure 13: Refrigerant Evacuation Unit

Appendix A

GNWT ENR Brochure for Household Hazardous Wastes

HOUSEHOLD HAZARDOUS WASTES

Household Hazardous Wastes (HHW) are products used in your home, workplace and places of leisure and recreation. They can be flammable, corrosive, explosive or toxic, and harmful to you and the environment if they are not handled properly. Household hazardous wastes are materials like household cleaners, paints, batteries, solvents, oil, pesticides, fertilizers, mercury items, and aerosol cans.



REDUCE YOUR USE!

Avoid disposal of household hazardous waste.

- Purchase only what you need
- Share leftover materials
- Choose environmentally friendly alternatives
- Visit www.lesstoxicguide.ca for environmentally friendly products

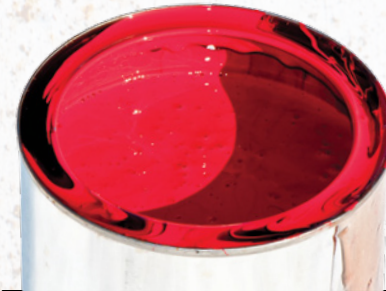
CHOOSE LESS HARMFUL PRODUCTS

- Choose products low in phosphates, chlorine, dyes and perfumes.
- Water-based (acrylic/latex) paints contain less toxic solvents and thinners.
- Pull weeds by hand or spray with natural chemicals.

HHW STORAGE

All hazardous materials should be clearly labeled and stored in secure containers away from children and pets. Hazardous materials should never be stored in food containers and they should never be poured down the drain or thrown into your household garbage. Manufacturers' labels provide additional information about storage, transportation, and proper disposal.

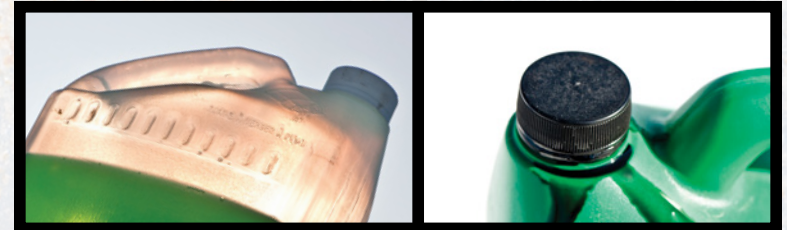
HOUSEHOLD HAZARDOUS WASTES SHOULD BE BROUGHT TO AN HHW COLLECTION SITE



PAINTS, STAINS, AND ADHESIVES KEEP FROM FREEZING FOR RE-USE!

Newer paint (oil & acrylic/latex), stains, and some adhesives contain less toxic materials and therefore have a greater re-use potential if they have not been frozen or exposed to air for extended periods of time.

Older oil-based paints and marine paints contain greater amounts of heavy metals and solvents which are toxic to humans, animals, and the environment. Paints, stains, and adhesives should be brought to a HHW collection event for disposal.



SOLVENTS, FUEL, OIL AND ANTIFREEZE KEEP SEPARATE AND LABEL YOUR CONTAINER!

Solvents, fuel, oil, and antifreeze contain toxic materials and should be kept in secure containers away from children and pets. Used oil can be recycled or used for heat recovery in local approved burners. Flammable liquids must be stored in clearly marked, secure containers away from sparks and flames and brought to a HHW collection event for disposal.



BATTERIES

USE RECHARGEABLE BATTERIES - SAVE MONEY!

Lead Acid Batteries Greater than 1kg

Lead acid batteries greater than 1kg (usually found in boats and automobiles) should be disposed of at an approved community facility, or brought to a HHW collection event for disposal.

Rechargeable Batteries

Most rechargeable batteries, like those found in cellular phones, radios, portable tools, computers, and other electronic equipment contain toxic substances and should be disposed of through a HHW collection event or through the Rechargeable Battery Recycling Corporation (RBRC). Call 1-800-8-BATTERY or visit www.rbrc.org for more information. If you can't find a RBRC recycling box in your community, consider starting your own!

Disposable Batteries

Disposable alkaline batteries (sizes AAA - D and 9 volt) produced in North America no longer contain toxic substances, like mercury, and they are recyclable. Button cell batteries found in watches contain small amounts of mercury.

Alkaline and rechargeable batteries should be segregated and brought to a HHW collection event for disposal.

PESTICIDES

Pesticides, including insect repellents, herbicides, and wood preservatives are toxic and should be stored in secure containers to minimize human and animal exposure.

FERTILIZERS

Fertilizers are considered to have a low level of toxicity, but have the potential to react with other compounds and should always be kept away from flammable materials. Pesticides and fertilizers should be brought to a community HHW collection event for disposal.



EXPIRED MEDICATION

KEEP OUT OF THE SEWERS AND SEPTIC TANKS!

Unwanted or expired medication should be returned to the point of purchase wherever possible. Medication may also be stored in a secure container, labeled and brought to an HHW collection event for disposal.



MERCURY

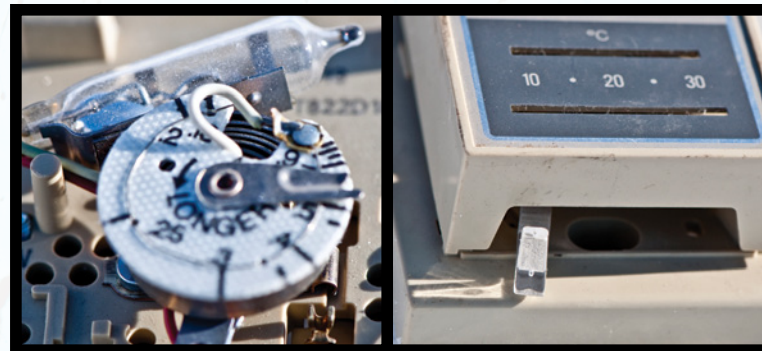
Fluorescent Bulbs

Fluorescent Bulbs save energy but contain small amounts of Mercury

Thermostats and Thermometers

Thermostats and thermometers contain high amounts of mercury.

Mercury containing items should be brought to a HHW collection event or a community bulb collection facility for disposal.





PROPANE TANKS AND AEROSOL CANS

Propane tanks and aerosol cans are potential explosion hazards and are dangerous to disposal facility operators as well as the public. Check your community listings for an appropriate place to dispose of propane tanks. Aerosol cans should be stored in a secure location and brought to a HHW collection event for disposal.



HOUSEHOLD CLEANERS

MIXING HOUSEHOLD CLEANERS CAN PRODUCE TOXIC GASES

Many household cleaners contain low amounts of toxic, synthetic chemicals, and other compounds. They should be stored in a secure container, away from children and pets, and should never be mixed. Unwanted household cleaners should be brought to a HHW collection event for disposal.

Another good resource for cleaner alternatives can be found at www.turi.org.



REMEMBER

Household Hazardous Waste should always be kept out of reach of children and pets, and receive proper storage, transportation, and disposal.

MATERIALS ACCEPTED AT HHW COLLECTION EVENTS AND COLLECTION SITES

- | | |
|---|---|
| Abrasive cleaners | Kerosene |
| Acetone | Laundry stain removers |
| Aerosol paints & sprays | Laundry starch |
| Air fresheners (aerosol) | Lighter fluid |
| All-purpose cleaners (solvent based) | Liquid cleaners |
| Ammonia | Lye |
| Ant/wasp spray | Mildew removers |
| Antifreeze | Muriatic acid |
| Autobody filler | Nail polish & remover |
| Barbecue starters | Oven cleaners |
| Batteries (alkaline, lead acid, rechargeable) | Paint |
| Bleach | Pharmaceuticals |
| Brake fluid | Photographic chemicals |
| Butane refills | Power steering fluid |
| Car waxes & polishes | Propane gas cylinder |
| Carbon tetrachloride | Rubbing alcohol |
| Contact cement | Septic tank degreaser |
| Degreasers (petroleum based) | Shoe polish |
| Disinfectants | Silver & brass polish |
| Drain cleaners | Solvents, (turpentine, varnish, lacquers) |
| Fertilizers | Spot removers |
| Floor wax strippers | Thermostats |
| Fluorescent light bulbs | Thermometers |
| Fuel | Toilet cleaners |
| Fuel additives | Transmission fluid |
| Grease | Tub & tile cleaners |
| Hair sprays (aerosol) | Used oil |
| Insecticides | Weed killers |
| | Windshield washer fluid |
| | Wood preservatives |

WHERE DOES HHW GO WHEN IT'S COLLECTED?

Hazardous waste that cannot be managed locally is transported in secure containers to hazardous waste treatment facilities.

HAZARDOUS WASTES **NOT** ACCEPTED AT HHW COLLECTION EVENTS

- ⚠ No waste from businesses, industries or institutions
- ⚠ No explosives
- ⚠ No infectious materials
- ⚠ No radioactive waste
- ⚠ No ammunition

*Special arrangements may be made if you call in advance.
Please call (867) 920-8044.

PROTECT OUR ENVIRONMENT AND KEEP HAZARDOUS WASTE OUT OF OUR SEWERS AND LANDFILLS!



Appendix B

Hazardous Waste Site Record

Appendix C

Paulatuk Waste Shipment Correspondence

Invoice



KBL Environmental Ltd.
PO Box 1895
17 Cameron Rd.
Yellowknife, NT X1A 2P4

Date Feb 5, 2018	Page 1
Invoice Number OE2018	

Sold To:

Incorporated Hamlet of Paulatuk
Box 98
Paulatuk, NT X0E 1N0

Ship To:

Incorporated Hamlet of Paulatuk
Box 98
Paulatuk, NT X0E 1N0

Manifest No.	BOL No. YK0000001813	BOL Date Oct 25, 2017	Customer No. INC001	PO Number	Ship Via HAY	Terms 30DAYS
---------------------	--------------------------------	---------------------------------	-------------------------------	------------------	------------------------	------------------------

Qty. Ord.	Item Number	Description	Unit Price	UOM	Extended Price
26,000.	BU-WLM	WASTE LEACHATE - MIXED BULK	0.35	L	9,100.00
1.00	MB-PP	PAINT - PAINT	610.00	MEGABAG	610.00
9.00	PA-ACFL	ADHESIVE CONTAINING FLAMMABLE LIQUID	45.00	PAIL	405.00
2.00	MB-NRSOD	NON REGULATED SOLIDS-OILY DEBRIS	375.00	MEGABAG	750.00
6.00	MISC	FREIGHT AND DELIVERY ON GREASE PAIL SKIDS	200.00	EA	1,200.00
9.00	MISC	FREIGHT AND DELIVERY ON PROPANE TANKS	10.00	EA	90.00
1.00	TO-FLF	FLAMMABLE LIQUIDS-FUEL	475.00	TOTE	475.00
150.00	EA-NRSED	NON REGULATED SOLIDS-EMPTY DRUMS 83 x Partial, 67 x Empty 1000L Consolidated from drums	37.50	DRUM	5,625.00
6.00	TT	6 x Hours Tech Time TECHNICIAN TIME	85.00	EACH	510.00

<p>Comments: NT14677-8, NT14678-6, NT14679-4</p> <p>accounting@kblenv.com GST/HST Registration #: 843759747</p>	<p>Tax summary:</p> <p>GST 938.25</p>	<p>Subtotal</p> <p>Total sales tax</p> <p>Total amount</p> <p>Amount due</p>	<p>18,765.00</p> <p>938.25</p> <hr/> <p>19,703.25</p> <hr/> <p>19,703.25</p>
--	--	--	--



Marine Transportation Services
 Department of Infrastructure
 #1, 104 Street
 Hay River, NT X0E 0R9

Government of Northwest Territories
 Gouvernement des Territoires du Nord-Ouest

INVOICE

Booking # SQ00421
 Invoice # SI000528
 10/20/17
 Page: 1

Bill Hamlet of Paulatuk
 To: PO Box 98
 Paulatuk, NT X0E 1N0
 Canada
 LARRY

Ship Hamlet of Paulatuk
 To: PO Box 98
 Paulatuk, NT X0E 1N0
 Canada
 LARRY

GST/HST Registr R107442691
 Ship Via Paulatuk
 Ship Date 09/12/17
 Terms

Customer ID C0090
 P.O. Number B1517
 P.O. Date 09/12/17
 SalesPerson

Item/Description	Unit	Qty	Weight	Cubage	Revenue	Tons	Rate Basis	Unit Price	Extra	Total Price
3283 (C-GENNONSTACK) Pallet: Toles (2)	Each	1	4,894	64	2,2199	Revenue Ton		291		645.99
3332 (C-GENNONSTACK) Container Flat: 7 Toles	Each	1	18,785	800	9,0614	Revenue Ton		291		2,636.87
3333 (C-GENNONSTACK) Container Flat: Drums, White Bags	Each	1	4,474	800	9,0614	Revenue Ton		291		2,636.87
3334 (C-GENNONSTACK) Container Flat: Drums, Crates, Pails, Ballerles	Each	1	10,935	800	9,0614	Revenue Ton		291	D	3,164.24
3335 (C-GENNONSTACK) Pallet: White Bag (1)	Each	1	286	64	0,7249	Revenue Ton		291		210.95
3336 (C-GENNONSTACK) Rlg Mat: Pallets w/ Drums	Each	1	5,180	1,087	12,0819	Revenue Ton		291		3,515.83
3337 (C-GENNONSTACK) Container Flat: Toles (10)	Each	1	17,640	800	9,0614	Revenue Ton		291		2,636.87
3338 (C-GENNONSTACK) Container Flat: Toles (8)	Each	1	17,442	800	9,0614	Revenue Ton		291		2,636.87
3339 (C-GENNONSTACK) Container Flat: Drums	Each	1	2,845	800	9,0614	Revenue Ton		291		2,636.87
3340 (C-GENNONSTACK) Container Flat: Drums, White Pails, Bags, Crates	Each	1	6,174	800	9,0614	Revenue Ton		291	D	3,164.24

P.O. Number
 Rec'd on barge 1517 11/10/17

ENTERED
 Nov 8 11
 Bmw
 JH



• Manitoulin Transport Inc.
 • Manitoulin Logistics Inc.
 • Quebec Express Inc.
 • Ridesdale Transport Ltd.

• Farmer Cartage Inc.
 • Jet Transportation Ltd.
 • Lakeshead Freightways Inc.
 • Smooth Freight Ltd.

Invoice / Pro Bill
 Facture No. De Pro. No.

23486936

P.O. Box 390, 154 Hwy 540B,
 Gore Bay, Ontario P0P 1H0

Tel. (705) 222-1906
 Fax. (705) 282-2269

www.manitoulintransport.com

Date (y/m/d) 17/10/21	Bill of Lading/Connaissance NS	Reference/Référence	Biller/Facteur MLO	COLL / PPD PPD	Interline Freight Bill No./Fret interline numéro de facture
Shipper/Expéditeur GERALD ENNS % HAMLET PAUL 92009 MACKENZIE HAY RIVER, NT XOEORO			Consignee/Consignataire GENERAL SORAOP RECYCLING 4120 84 TH AVE EDMONTON, AB T5A		

Transfer to/Transférer à	A/A	I/O	Bill To/Facteur 6601057 GOVERNMENT OF N W T
--------------------------	-----	-----	---

Pieces	Description	Weight/Poids	Rate/Tarif	Amount/Montant
4	3434 KGS CONV TO LB BATTERIES DANGEROUS GOODS CHARGE DANGEROUS GOODS DOCUMENTS ATT'D CALL/EMAIL FOR DEL APP 780 953 7000 FUEL SURCHARGE @ 25 % Dim 192in L * 48in W * 36in H Dim 192in L * 48in W * 36in H Dim 192in L * 48in W * 36in H Dim 192in L * 48in W * 36in H FAK-70 N 20171024 15:40:03 LESS 66.0% DISCOUNT... BL:NS,PO:NS ACTUAL WEIGHT: 007571	7571	36.94	2796.73 35.75 26.50 237.72 1845.84-
	BILLED AS:	7571		1250.86
	*** PAYABLE IN CDN FUNDS ***			

#6/20-0820

For billing information, please call - Pour les informations de facturation, s'il vous plaît appelez
 (705) 282-2640 **Total 1,250.86**

G.S.T./H.S.T./T.P.S. # R103481925 Q.S.T./T.V.Q. # 1002600001

Terms: Net 21 days, 2% per month (24% per annum) on overdue accounts
 Termes: Net 21 jours, 2% per mois (24% par année) sur comptes en souffrance

Appendix D

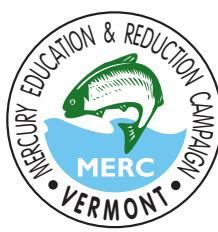
Household Mercury Switch Manual

HOUSEHOLD APPLIANCE MERCURY SWITCH REMOVAL MANUAL

SPRING 2002



PRODUCED BY:



Special Thanks to the following people and organizations for help in the development of this manual;

Gary Winnie of the Chittenden Solid Waste District (CSWD), Gary Hobbs of the Addison County Solid Waste District (ACSWD), The Northeast Kingdom Waste Management District (NEKWMD), The Association of Home Appliance Manufactures (AHAM), Purdue University, and the Vermont Recycling & Hazardous Waste Coordinators Networks.

Any questions, comments, corrections or requests for additional copies should be directed to the:

Vermont Agency of Natural Resources
Environmental Assistance Division
103 South Main Street, Laundry Building
Waterbury, VT 05671-0411

Attention: Thomas A. Benoit
Telephone: 802-241-3472
tombe@dec.anr.state.vt.us

This document is available on the Internet at:



TABLE OF CONTENTS

1.0	INTRODUCTION	1
2.0	REGULATORY BACKGROUND	3
	HOW TO USE THIS MANUAL	4
3.0	HOUSEHOLD APPLIANCE MERCURY REMOVAL	5
3.1	Chest Freezers	5
3.2	Washing Machines.....	7
3.3	Gas Ranges	9
3.4	Gas Hot-water Heaters	13
3.5	Sump and Bilge Pumps	14
4.0	MERCURY HANDLING, STORAGE AND DISPOSAL.....	15
4.1	Handling.....	15
4.2	Storage	15
4.3	Disposal	15
5.0	MERCURY SPILL CLEAN-UP	16

APPENDICES

APPENDIX A	Solid Waste Districts, Alliances and Municipalities Contact List
APPENDIX B	Mercury Spill Clean-up Contractors
APPENDIX C	Hazardous Waste Transporters
APPENDIX D	Mercury Recyclers
APPENDIX E	Mercury-Added Products Fact Sheet
APPENDIX F	Fluorescent Lamps Fact Sheet

REFERENCES

1.0 INTRODUCTION

Mercury (Hg) is one of the most widespread, persistent and toxic contaminants in our environment. Its incorporation into many products and its emission from combustion processes has resulted in well documented instances of population poisonings, high level occupational exposures, and worldwide, chronic, low-level environmental exposures. About two-thirds of the mercury in the atmosphere comes from human sources such as coal burning power plants and incinerators, and one-third from natural sources such as volcanoes and forest fires. The amount of mercury flowing into our lakes is between two and four times what flowed into them 100 years ago⁸.

In the environment, mercury is found in various forms and complexes. Atmospheric mercury mixes with rain and snow and falls into lakes, rivers and watersheds. Once mercury enters a waterway, natural processes convert a small proportion of it to methyl mercury. Methyl mercury, one organic form of mercury, can accumulate up the food chain in lakes, ponds and reservoirs which results in high concentrations in predatory fish.

When certain mercury-tainted fish are consumed by humans, the levels of mercury can impair development of the nervous system in the fetus and in young children, affecting sensory, motor and cognitive functions, and resulting in such problems as difficulty in learning to read and inability to concentrate. Vermont's relatively pristine waters have not been spared from this regional and global problem. In addition to fish consumption advisories that recommend limiting consumption of certain fish in certain bodies of water, recent studies have shown that 12 percent of Vermont's lakes have sufficient mercury in their food chains to put common loons at considerable risk of toxic effects.

In order to prevent the continued release and build-up of mercury (in all forms) in the environment, many states including Vermont are currently working towards eliminating major sources of mercury releases. The Governors of the New England States and the Premiers of the Eastern Canadian Provinces have endorsed a regional goal of "the virtual elimination of the discharge of mercury into the environment" from man-made sources. Vermont has addressed mercury elimination through its Mercury Education and Reduction Campaign (MERC), which has included thermometer exchanges, school clean-outs, retailer and contractor mailings, dairy manometer exchanges, pharmacy pledges and various other outreach efforts to remove mercury from the solid waste stream.

One of Vermont's other efforts is the removal of mercury from discarded household appliances or "white goods". Many of these white goods, which are currently being collected for their scrap metal value, contain mercury switches and thermocouples. Mercury was used in household appliances due to it being a highly reliable means for electrical switching in varied temperature and moisture conditions⁴.

When "white goods" are processed for scrap metal, mercury may be released to the environment. In fact, when white goods are processed (shredded) for scrap metal, there are three distinct by-products. These are classified into ferrous, non-ferrous metallic and nonmetallic components¹. It is the "fluff" or non-metallic components that many of the hazardous constituents in household appliances adhere to, including mercury². These hazardous components are then available to be released either through smokestack emissions at smelters, incinerators or through landfill leachate from intact products or ash from their incineration¹. The diagram on the following page details how mercury cycles through the environment.

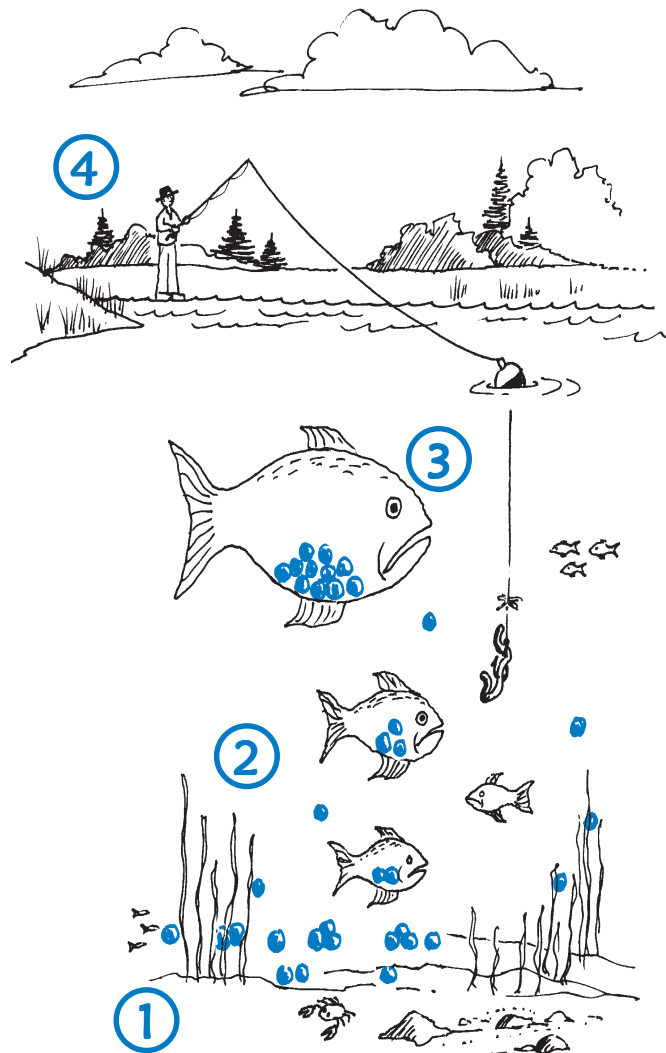
How Does Mercury Get Into Fish?

Once in a lake or river, mercury is converted to methylmercury by bacteria and other processes. Fish absorb methylmercury from their food and from water as it passes over their gills. Mercury is tightly bound to proteins in all fish tissue, including muscle. **There is no method of cooking or cleaning fish that will reduce the amount of mercury in a meal.**

Methylmercury accumulates as you move up the food chain:

1. Methylmercury in the water and sediment is taken up by tiny animals and plants known as plankton.
2. Small fishes eat large quantities of plankton over time.
3. Large predatory fish consume many smaller fish, accumulating methylmercury in their tissues. The older and larger the fish, the greater the potential for high mercury levels in their bodies.
4. Fish are caught and eaten by humans and animals, causing methylmercury to accumulate in their tissues.

The State of Vermont Fish Contaminant Monitoring Program has been monitoring the levels of mercury in fish tissue since 1987. Measureable concentrations have been observed in 95% of the samples collected from lakes and rivers across the state. The highest amounts of mercury are generally found in older fish of species which consume other fishes. The species which contain the greatest amounts of mercury are walleye from Lake Champlain, smallmouth bass, and chain pickerel. The lowest mercury levels are found in pumpkinseed sunfish, brown bullhead, and brook trout from streams. The Vermont Department of Health has issued a fish consumption advisory which recommends that fewer meals be consumed of species with greater than average mercury levels. The advisory is also more protective of women of child-bearing age and children under age 7. For more information on consumption advisories call the Department of Health toll-free at 1-800-439-8550.



The purpose of this manual is to address the removal of mercury switches and thermocouples prior to appliances being processed for their scrap metal. By educating individuals on how to remove mercury prior to metal reclamation, we all can help manage mercury wastes properly and keep mercury out of the environment.

2.0 REGULATORY BACKGROUND

Mercury is an environmental concern because it is a heavy metal that can accumulate in living tissues and cause adverse health effects. When a mercury containing device is disposed of in a landfill or incinerator, the mercury in it can escape to contaminate air, soil, surface water and ground water. For a number of years, the Vermont Department of Health has issued health advisories warning people to limit consumption of freshwater fish caught in Vermont due to elevated levels of mercury in some fish species. When mercury is spilled in the home or workplace, the silvery liquid metal can evaporate and be breathed in by everyone in the building. Mercury affects the human brain, spinal cord, kidneys and liver. It affects the ability to feel, see, taste and move. Long term exposure can result in symptoms that get progressively worse and lead to personality changes, stupor and coma.

Mercury is intentionally added to many familiar products. Some of these include:

- fluorescent and high intensity discharge (HID) lights
- certain types of thermometers and thermostats
- heat sensors for gas pilot lights
- tilt switches in automobiles and appliances
- silent wall switches and electric relays
- vacuum gauges, barometers and manometers

For the last 20 years, mercury-containing waste from business, industry and institutions has been considered a hazardous waste because it often fails standard EPA toxicity test limits. More recently, a less restrictive waste handling option has been added to both state and federal hazardous waste regulations for certain mercury-containing wastes. These wastes are called “Universal Wastes” because they are equally likely to come from either regulated or unregulated sources. Only thermostats and hazardous waste (mercury-containing) lamps are currently listed as Universal Wastes. Wastes that are listed as “Universal Wastes” have reduced requirements for reporting, handling and storage (See Vermont Hazardous Waste Management Regulations, Subchapter 9, *Universal Waste Management Standards* for more information.). By having less restrictions on mercury-added product management, proper management can be easily facilitated.

The Vermont Agency of Natural resources is in the process of revising its “Universal Waste” rule to include all categories of mercury-added products. In the interim, to facilitate removal of as many of these products as possible from the solid waste stream and promote proper management of the collected mercury, these waste materials may be handled under existing provisions of the Vermont Hazardous Waste Management Regulations (See Subchapter 9, *Universal Waste Management Standards*) in the same manner as “Universal Waste Thermostats”.

In 1998, the Vermont legislature passed a bill to decrease the amount of mercury in the State’s solid waste. Under one provision of the bill, labeled mercury-added products are required to be separated

from the trash and are banned from landfill disposal. After March 1, 2000, all mercury-added products are required to be labeled under Vermont Law. Municipalities and Solid Waste Districts are required to provide collection programs for these materials. The Vermont law applies equally to households, farms, businesses and industries. The following mercury-added products are banned from landfill disposal and/or are required to be labeled in Vermont:

- thermostats or thermometers
- switches individually or part of other products
- medical or scientific instruments
- electric relays or other electric devices
- lamps
- batteries, other than button cells

HOW TO USE THIS MANUAL

This manual covers:

- the purpose of mercury in particular appliances
- its location and use
- how to safely and properly remove it
- how to safely store mercury-added products
- the proper methods of disposal or recycling
- mercury spill clean-up
- lists of hazardous waste transporters, mercury recyclers and spill clean-up firms

Since we are constantly discovering additional products with mercury-added components, this manual remains a work in progress. Please let us know of any additional products that you feel should be added to this manual.

3.0 HOUSEHOLD APPLIANCE MERCURY REMOVAL

Safety Note: Proper personal protective equipment should be used at all times (i.e, safety glasses, gloves, tyvek suit and in the event of a spill a respirator and mercury cartridges). In addition, spill equipment and storage material should be on-hand prior to any mercury-added device removal.

All appliances should be unplugged from an electrical outlet prior to any mercury switch removal. Appliances that have had these devices removed should be disabled to prevent future use (i.e, cut the electrical cord, or disable the gas feed line). All appliances that have had their mercury switches removed should be handled as scrap metal for recycling (not to be reused as a home appliance). All other hazardous components must be properly removed and disposed of (including but not limited to chlorofluorocarbons (CFCs) and polychlorinated biphenyls (PCBs) prior to scrap metal recycling.

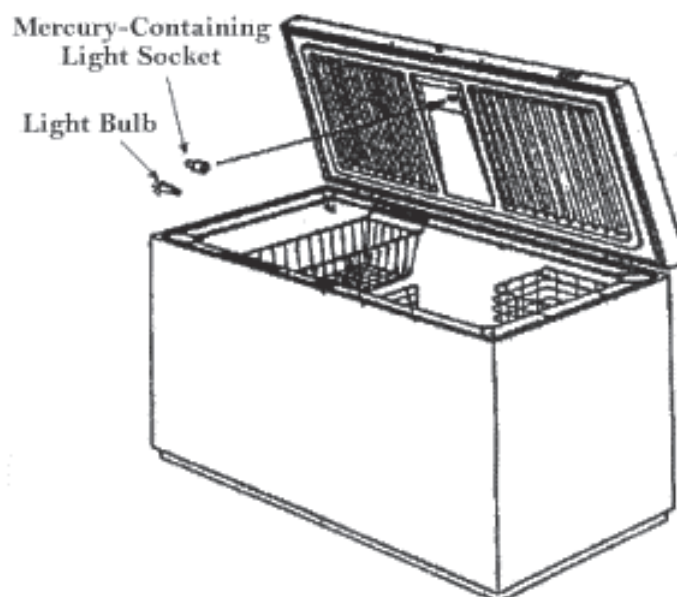
In case a switch breaks during the removal process, please follow the mercury spill clean-up instructions on page 20.

Note: Once these mercury-added products are removed, proper handling, storage and disposal are described on page 19 and in Appendix E.

3.1 Chest Freezers

Some chest freezers are made with a mercury switch inside the freezer cover light socket (see Figure below). The mercury engages two contact points when the lid is opened thus completing the electrical circuit and turning on the light. All freezer manufacturers have stopped using mercury as a switching mechanism and begun using a mechanical switch by January 1, 2000. If there is no visible push button switch mechanism, the freezer is likely to have a lid mercury tilt switch³.

Chest Freezer with Mercury-Containing Light Socket.



Reprinted with permission from the Association of Home Appliance Manufacturers, Appliance Recycling Information Center, Bulletin #8, Mercury in Home Appliances.

The following procedure should be used for removal of the mercury tilt switch.

CHEST FREEZER MERCURY SWITCH REMOVAL

ESTIMATED REMOVAL
TIME: 1-5 MINUTES



STEP 1.

Open the freezer lid and look for a manual switch, similar to the one shown above. If it has a manual switch, the appliance can be handled as scrap metal (after removal of CFCs).



STEP 2.

Locate the light socket on the underside of the lid (on some freezers you may have to remove a plastic light cover).



If there is no manual switch, proceed to **STEP 2.**

STEP 3.

Remove the light bulb and properly discard.



STEP 4.

Remove the plastic housing (either by unscrewing it or breaking it off).



STEP 5.

Gently pull the light socket out of its mounting bracket (due to some lights having an in line mercury switch see Reference Photo 2 below).



STEP 6.

Cut or remove the attached wires.



STEP 7.

Remove and properly dispose of the entire light socket.



REFERENCE PHOTO 1.

Assorted mercury freezer switches for disposal.



REFERENCE PHOTO 2.

Chest freezer light with an inline mercury switch (glass ampule).



3.2 Washing Machines

Mercury switches were used in a small number of washing machines manufactured prior to 1972 because of their ability to reliably function in a high-moisture environment. Most washing machines with mercury switches will have passed through the recycling stream by 2010. Mercury switches were used for two different applications in washing machines, both of these uses were for consumer protection.

One application of the mercury switch was used to detect a lid opening and engage a brake to quickly stop the washer drum from moving. This feature is particularly important when the washer is in a spin cycle because it reduces the risk of a consumer being injured by reaching into a spinning basket. This switch is located between the washer tub and the cover for the tub area of the washer and is activated when the lid of the washer is lifted.

Another use for mercury switches in washing machines was in the dynamic stabilizing system to prevent a severe out-of-balance condition (only on certain models). This switch worked by breaking the circuit when the washing machine was severely out of balance. This switch is located on the back of certain washing machine models and is activated when the washing machine is severely out of balance.

These switches can be identified and removed using the following procedures.

WASHING MACHINE MERCURY SWITCH REMOVAL

ESTIMATED REMOVAL
TIME: 5-10 MINUTES



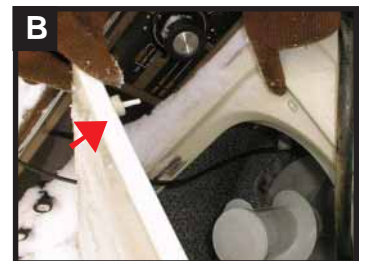
STEP 1.

Open the lid on the washer and look for a non-mercury mechanical switch. These switches come in various sizes, shapes and locations. You should also be able to hear an audible “click” when a mechanical switch engages and disengages (with the opening and closing of the lid). If there is no mechanical switch continue to STEP 2. Photos A and B are examples of non-mercury mechanical switches.

Non-mercury mechanical switch examples:



A) back tab switch



B) front tab switch.

Once you have determined that there is no mechanical switch, the following procedure can be used to remove the mercury switch.

STEP 2.

Pry off the top of the washing machine as shown in figure a. or remove any fasteners from the lid as shown in figure b.



STEP 3.

On the underside of the lid, attached to the lid mounting rod, is an encapsulated mercury switch.



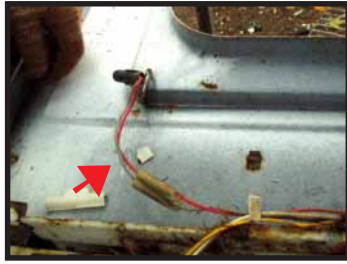
STEP 4.

Remove the switch from the bracket.



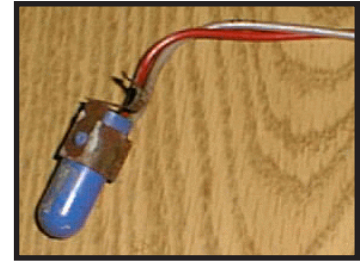
STEP 5.

Cut or remove any attached wires.



STEP 6.

Properly dispose of the entire washing machine mercury switch.



Another use for mercury switches in washing machines was in the dynamic stabilizing system to prevent a severe out-of-balance condition (only on certain models). Only through removal can you distinguish between a manual switch and a mercury switch. The mercury will be visible.

SEVERE OUT-OF-BALANCE SWITCH REMOVAL

ESTIMATED REMOVAL TIME: 5-10 MINUTES



STEP 1.

Locate the dynamic stabilizing switch on the back of the washing machine.



STEP 2.

Remove the fastening bolts.



STEP 3.

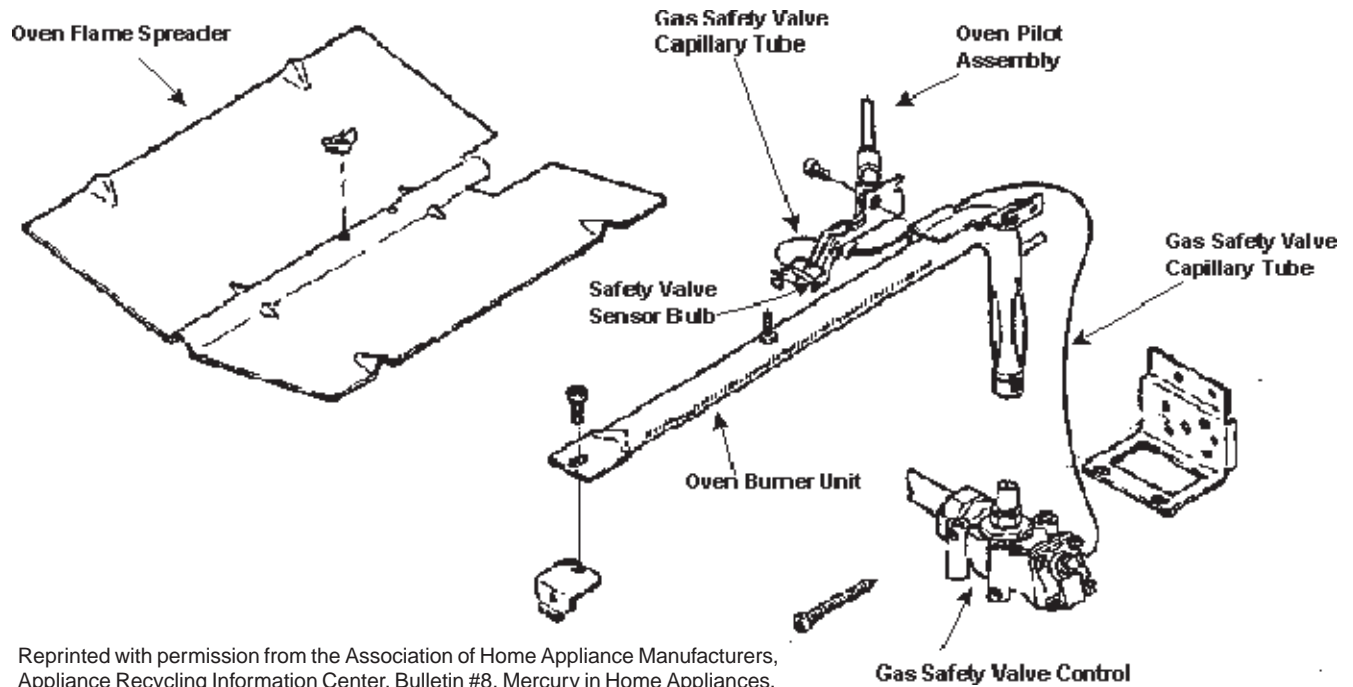
Disconnect the attached wires and properly dispose of the switch.



3.3 Gas Ranges

Gas ranges are ignited using either an electronic ignition system or a pilot-light. Pilot-light ranges require a mechanical safety device to detect whether the pilot-light is on and shut off the supply of gas to the burner when the pilot-light is not burning. Otherwise, the potential exists for a dangerous quantity of gas to build up in the oven. The diagram on the following page depicts the mercury containing control device on the gas burner assembly.

Gas safety valve (flame sensor) assembly.



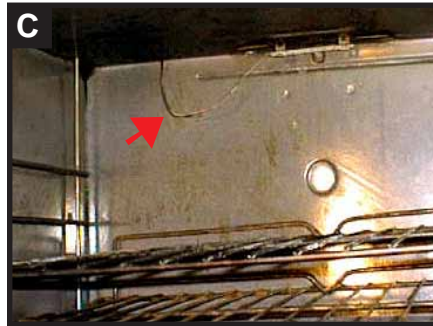
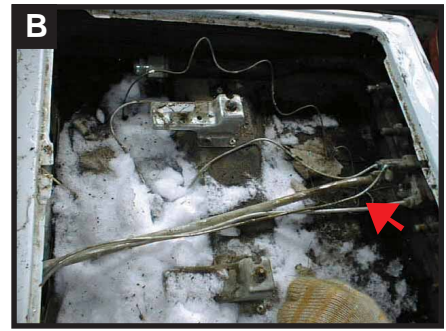
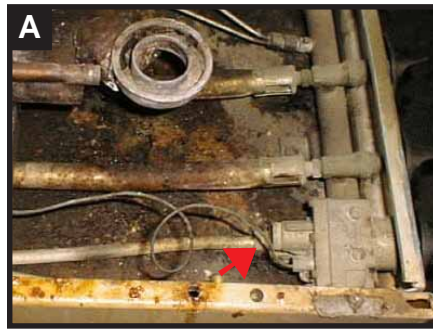
The gas burner is located beneath the oven cavity in the broiler pan. (*Note: All appliances manufactured after March 1, 2000 should be labeled if they incorporate a mercury-containing device.*) Gas ranges contain many temperature sensing probes and switches. The following procedure shows you how to distinguish the non-mercury probes and switches from the mercury switches (many times within the same appliance). Many of your stainless steel safety valve capillary tubes and sensor bulbs are mercury-containing devices while copper safety valve capillary tubes and sensor bulbs are non-mercury containing devices. **As a general rule, magnetic metals are mercury-containing probes while non-magnetic metals are non-mercury containing probes.** This may be difficult to distinguish with baked on food. What may appear copper maybe stainless steel coated with baked on food. Removal of any baked on food maybe necessary prior to determining metal type.

Temperature capillary tubes and bulbs found within ovens or below upper burners are usually copper probes. A copper probe is good indication of a non-mercury containing device. These capillary tubes and bulbs are instead filled with an oil or sodium-potassium mixture. Photos A thru D on the following page show some examples of non-mercury probes.

NON-MERCURY TEMPERATURE PROBES

These photos are examples of non-mercury temperature probes in a gas range and oven. Photos A and B show the top view of a gas range after the burner surface has been removed. **Note that these capillary tubes and bulbs start at the temperature control knob.**

Photos C and D show the oven control temperature capillary tubes and bulbs (top of the oven cavity) which continue from the oven control knob into the oven cavity.



If you have determined that the gas oven capillary tubes and bulbs are mercury containing, the following procedure can be used to identify and remove the mercury gas safety valve control assembly.

GAS RANGE MERCURY GAS SAFETY VALVE CONTROL ASSEMBLY REMOVAL PROCEDURE

ESTIMATED REMOVAL TIME: 15-20 MINUTES



STEP 1.

Remove the broiler pan drawer.



STEP 2.

Once the drawer is removed you can view the burner assembly inside.



STEP 3.

When viewing the burner assembly, the small capillary tube (pointed out) is indicative of a mercury sensor switch.



STEP 3A.

Burner assemblies without a capillary tube but instead with an electronic pilot flame sensor (identifiable by the two wires) are **non-mercury**.



STEP 3B.

For gas ranges with a bracket covering the pilot, simply bend the bracket out of the way to view the wires indicating an electronic pilot sensor (non-mercury sensor).



Ranges without a capillary tube can be sent to scrap metal after making sure there is no fluorescent backlighting (see STEP 16) or PCBs.

For ranges with a capillary tube, **proceed to STEP 4.**

STEP 4.

If you have a capillary tube (like the one in the photo), you will now have to remove the burner assembly, valve and all attached gas fittings.



STEP 5.

Start by removing the key (sometimes a screw or a pressure fit) holding the burner assembly in.



STEP 6.

With the burner assembly loose, **proceed to STEP 7.**



STEP 7.

Disconnect the gas feed line by loosening the fitting or cutting the gas line.



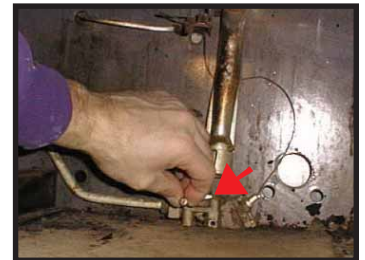
STEP 8.

Disconnect the pilot gas feed line by loosening or cutting (there may sometimes be two feed lines).



STEP 9.

Remove the two screws holding the gas safety valve control in place.



STEP 10.

The entire burner assembly and valve are now ready to be removed. Note there is no screw or pin holding the oven burner unit, this is an example of a pressure fitting oven burner unit.



STEP 11.

Gas range with the oven burner unit and gas safety valve control removed.



STEP 12.

The removed oven burner unit and gas safety valve control.



STEP 13.

Remove the screw holding the gas safety valve control and gas safety valve capillary tube and bulb to the oven pilot assembly.



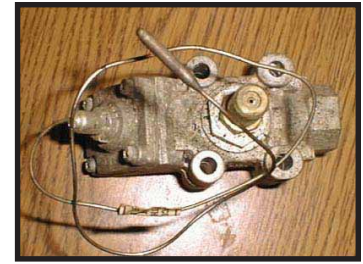
STEP 14.

Carefully pull the gas safety valve capillary tube and safety valve sensor bulb back through the bracket.



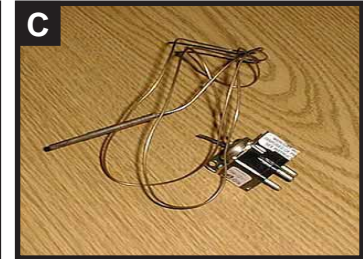
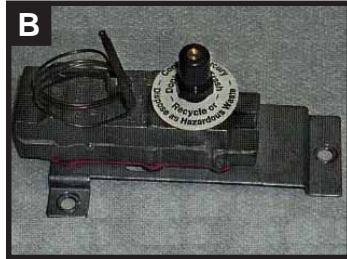
STEP 15.

The entire gas safety valve control, gas safety valve capillary tube and safety valve sensor bulb are now ready for proper disposal. **Proceed to STEP 16.**



EXAMPLES OF SOME MERCURY GAS SAFETY VALVE CONTROLS, CAPILLARIES AND BULBS

Photos A & B show complete mercury gas safety valve control, capillary and bulb. Photo C shows a gas auto pilot probe.



GAS RANGE FLUORESCENT BACKLIGHTING REMOVAL

ESTIMATED REMOVAL TIME: 1-2 MINUTES



STEP 16.

Prior to disposal, all stoves should be inspected to make sure that there is no fluorescent backlighting or PCBs. Some backlighting contains fluorescents and PCBs that come in various shapes and sizes (in addition to the one shown in the photos) and should be carefully removed and disposed of properly.



3.4 Gas Hot Water Heaters

Although all the current literature states that mercury was not used in residential hot-water heaters, the following procedure has been included to help prevent any mercury-added thermocouples from entering the waste stream and eventually the environment. Use the following procedure to properly identify and remove any mercury-containing thermocouples (usually commercial hot-water heaters of 100 gallons or more).

GAS HOT WATER HEATER MERCURY THERMOCOUPLE REMOVAL

ESTIMATED REMOVAL TIME: 5-10 MINUTES 

STEP 1.
Locate the temperature control unit.



STEP 2.
Determine if there is an electronic flame sensor (determined by the presence of wires) or if there is a mercury thermocouple.



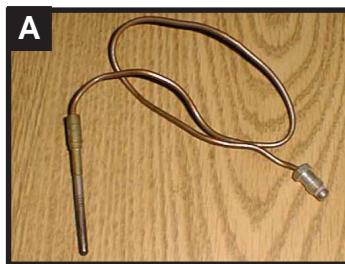
STEP 3.
Use a magnet to determine if it is indeed a mercury probe (non-magnetic probes are non-mercury).



STEP 4.
If the probe is mercury, simply remove the bottom of the heater and loosen the nut attaching the probe. Then properly dispose of the mercury thermocouple.

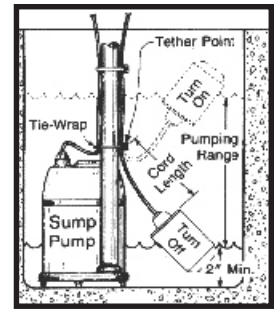


PHOTO A.
A non-mercury temperature probe. Notice that this probe is copper, which is a good indication of a non-mercury containing device.



3.5 Sump and Bilge Pumps

Another use for mercury was as a switch in sump and bilge pumps. This switch, which functioned very reliably in the high moisture environment, turned on and off based on the corresponding water level (see sump pump diagram at right). As the water level rises, so does the float ball and wire (a wire attached to the float is a good indication of a mercury sump pump) which would then tilt the mercury switch, completing the electrical circuit that turns on the pump. As the water level receded the electrical circuit would then be broken and the pump would turn off.



Basic sump pump operation (mercury switch). Reprinted with permission from Purdue University.

SUMP PUMP MERCURY REMOVAL

ESTIMATED REMOVAL TIME: 1-2 MINUTES



A mercury-free sump pump. Notice the metal guide and no attached wires.

The sump pump on the left is an example of a mechanical sump pump. This pump works on the same principle that as the float ball rises up with the water it would turn on the pump (mechanical switch) and when the water recedes it would sink down with the water and shut the pump off. As can be seen in the photo on the left, a metal guide is used instead of a wire. This is a good indication of a non-mercury sump pump.



Sump pump float containing mercury.

Once you have determined whether or not it is a mercury sump pump, the wire attaching the float can simply be cut and the whole float properly disposed of (see photo at right).

BILGE PUMP MERCURY REMOVAL

ESTIMATED REMOVAL TIME: 1-2 MINUTES



Bilge pump containing mercury.

Bilge pumps work on the same principle as a sump pump. By rotating on a stationary point (see drawing on right) with the fluctuations in water level either up or down, the bilge pump would turn on or off. Several of the newer models use this method with a rolling steel ball instead of mercury to complete the electrical circuit. This can be determined by simply shaking the bilge pump. A steel ball bearing will be easily discerned from liquid mercury.



Automatic switch bilge pump.

Once you have determined it is a mercury bilge pump, you can simply remove the entire pump and properly dispose of.

4.0 MERCURY HANDLING, STORAGE AND DISPOSAL

Once mercury devices are removed, they should be properly handled, stored and disposed of. The handling, storage and disposal protocols covered below are a best management strategy for individuals or businesses (non-profit and for profit) that generate less than 11,000 pounds of universal waste at anytime (all universal wastes combined). Individuals or businesses who will be generating more than 11,000 pounds should refer to Subchapter 9, the Universal Waste Management Standards in the State of Vermont Hazardous Waste Management Regulations.

Included for your convenience are two fact sheets, **Appendix E - Waste Mercury Containing Switches and Devices** and **Appendix F - Fluorescent Lamps**, which summarize handling, storage and disposal requirements for these products.

4.1 Handling

A mercury-containing switch or product should always be handled in a way that will prevent breakage. Also when removing mercury or mercury-added components from a product do so only over or in a containment device that will collect and contain any mercury released in the event of a mercury-added product breaking. Be sure to keep spill clean-up kits (See Section 5, Mercury Spill Clean-up) and equipment readily available and always ensure that there is adequate ventilation. **Any spilled mercury or any contaminated clean-up materials must be handled as a hazardous waste. For large spill clean-ups (more than 1 or 2 tablespoons) a firm specializing in mercury clean-up should be acquired (see Appendix B).** Anyone handling mercury or mercury-added products should use proper personal protective equipment (latex gloves, tyvek suit, safety glasses and a respirator with mercury cartridges if cleaning up a mercury spill) and be thoroughly familiar with proper mercury handling and emergency procedures (See Appendix E - Waste Mercury Containing Switches and Devices Factsheet).

4.2 Storage

All mercury-containing switches or products must be stored in containers that will prevent any breakage or leakage. These containers must be closed, structurally sound and compatible with the mercury-added products being stored. All containers of mercury-added products must be properly labeled with one of the following; "Universal Waste- Mercury-added Product(s)", or "Waste Mercury-added product(s)" or "Used Mercury-added products" and stored for no more than one year.

4.3 Disposal

Properly contained and labeled mercury-added products can be disposed of in three possible disposal routes. These are:

- Disposal through a local Solid Waste District, Alliance or Municipality. This is usually done through Household Hazardous Waste Collection events or facilities (see Appendix A for a list of Solid Waste Districts, Alliances and Municipalities).
- Disposal through a hazardous waste transporter (see Appendix C).
- Disposal through a mercury recycler (see Appendix D).

5.0 MERCURY SPILL CLEAN-UP

MERCURY SPILL KIT

At a minimum you should have the following supplies in the event of a mercury spill. Those removing and collecting mercury on a continued basis should consider adding a commercially available spill kit to these items.

- index cards
- respirator with mercury vapor cartridges
- sulfur powder
- flashlight
- rubber squeegee
- zinc or copper flakes
- tape
- Ziploc plastic bags
- paper towels
- plastic dust pan
- wide mouth plastic container with cover
- plastic trash bags
- latex gloves

Note: Most spill/safety equipment suppliers have complete spill kits for purchase. Contact the Agency of Natural Resources for purchasing information.

EMERGENCY MERCURY SPILL CLEAN-UP PROCEDURE

This clean-up procedure is only intended for small mercury spills. If the spill involves more than one or two tablespoons of free mercury or the material has splattered over a sizeable area, is in cracks and crevices or other difficult to clean places, or is on a non-disposable porous item such as wall to wall carpeting or upholstery, ***we recommend you retain an environmental firm with the equipment and expertise to perform the cleanup (see Appendix B) and call the Vermont Spills Hotline at 1-800-641-5005.***

- A) Wear latex gloves to prevent skin contact. Keep your hands away from your face-especially your eyes, nose and mouth. ***Before beginning any spill clean-up make sure that the area is adequately ventilated or you have a respirator with mercury vapor cartridges.***
- B) Carefully pick up any broken pieces of glass (***NEVER SWEEP OR VACUUM MERCURY***). Place them on a paper towel or tissue. Wrap or fold the paper towel, and place into a leak-tight plastic bag or sealable plastic container.
- C) Sprinkle sulfur powder on the spill area to control mercury vapors. Then, working from the outside of the spill area toward the center, push small mercury beads together with a card, stiff paper, or squeegee to form larger droplets. Put droplets into a leak-tight plastic bag or plastic container.

- D) Use the sticky side of a two-inch (or wider) duct or masking tape to pick up any remaining glass or mercury beads. Pay special attention to cracks and crevices. Place tape and debris in a leak-tight plastic bag or sealable plastic container.
- E) Use a flashlight to look all around the spill area. The light will reflect off the shiny mercury beads and make it easier to see them.
- F) Sprinkle sulfur powder on the spill area after cleaning up beads of mercury; a color change from yellow to brown indicates that mercury is still present and more cleanup is needed.
- G) Sprinkle zinc flakes or copper flakes (available at hardware stores) to amalgamate any small amounts of mercury which remain.
- H) When finished, carefully remove latex gloves and place them in a leak-tight plastic bag or sealable plastic container. Do not touch the glove fingertips or parts that may have come in contact with mercury. Place all the closed containers in a double plastic bag and tie the opening. Properly dispose through a hazardous waste transporter, mercury recycler (see Appendix C) or call your Solid Waste District, Alliance or Municipality (see Appendix A).
- I) Thoroughly clean your hands and body. ***Never wash contaminated clothing in a washing machine or remove contaminated clothing or apparel from a spill site. This will help prevent further site contamination.*** These should also be properly disposed of.

APPENDIX A

VERMONT SOLID WASTE DISTRICTS, ALLIANCES AND MUNICIPALITIES

ADDISON COUNTY SOLID WASTE MANAGEMENT DISTRICT

P.O. Box 573, Route 7 South
Middlebury, VT 05753
(802) 388-2333
Fax: 388-0037
email: acswmd@acswmd.org
Website: www.acswmd.org

Participating Towns:

Addison, Bridport, Cornwall, Ferrisburg, Goshen, Leicester, Lincoln, Middlebury, Monkton, New Haven, Orwell, Panton, Ripton, Shoreham, Starksboro, Vergennes, Waltham, Weybridge, Whiting

BENNINGTON REGIONAL PLANNING COMMISSION

Box 342
Arlington, VT 05250
(802) 375-9964
Fax: 375-1561

Participating Towns:

Arlington*, Dorset*, Manchester*, Pownal**, Rupert, Sandgate*, Shaftsbury**, Stamford, Sunderland
* town works closely with BRPC
** send mailings directly to town contact

Town Contacts:

Pownal: Steffan Strohmaier, Pownal Town Office, P.O. Box 411, Pownal VT 05261 Tel# 823-7757.
Shaftsbury: Dennis McCarthy, Asst. to Sel. Bd., P.O. Box 409, Shaftsbury VT 05262 Tel #442-4043.

CENTRAL VERMONT SOLID WASTE MANAGEMENT DISTRICT

137 Barre Street
Montpelier, VT 05602
(802) 229-9383 or 1-800-730-9475
Fax: 229-1318
email: fieldprograms@cvswwmd.com

Participating Towns:

Barre City, Barre Town, Berlin, Bradford, Cabot, Calais, Chelsea, East Montpelier, Hardwick, Marshfield, Middlesex, Montpelier, Northfield, Orange, Plainfield, Roxbury, Tunbridge, Walden, Washington, Williamstown, Woodbury

CHITTENDEN SOLID WASTE DISTRICT

1021 Redmond Road
Williston, VT 05495
(802) 872-8100
Fax: 878-5787
Recycling Hotline: 872-8111
E-mail: info@cswd.net

Participating Towns:

Bolton, Burlington, Charlotte, Colchester, Essex, Essex Junction, Hinesburg, Huntington, Jericho, Milton, Richmond, St. George, Shelburne, South Burlington, Westford, Williston, Winooski

GREATER UPPER VALLEY SOLID WASTE MANAGEMENT DISTRICT

96 Mill St. P.O. Box 58
North Hartland, VT 05052-0058
(802) 296-3688
Fax: 281-7088
E-mail: guvswd@valley.net

Participating Towns:

Bridgewater, Hartland, Norwich, Pomfret, Sharon, Strafford, Thetford, Vershire, West Fairlee, Woodstock

JOINT MUNICIPAL SURVEY COMMITTEE/SOLID WASTE ALTERNATIVE COMMITTEE

87 Halls Pond Road
Salem, NY 12865
(518) 9702
email: pam@starlitridge.com

Participating Towns:

Benson, Chittenden, Fair Haven, Middletown Springs, Pawlet, Rutland Town, Shrewsbury, Sudbury, Tinmouth, West Haven

LAMOILLE REGIONAL SOLID WASTE MANAGEMENT DISTRICT

29 Sunset Drive
Morrisville VT 05661-9788
(802) 888-7317
Fax: 888-6507
email: info@lrswmd.org

Participating Towns:

Belvidere, Cambridge, Craftsbury, Eden, Elmore, Hyde Park, Johnson, Morristown, Stowe, Waterville, Wolcott, Worcester

LONDONDERRY GROUP

Londonderry Recycling Coordinator
P.O. Box 118
South Londonderry, VT 05148
(802) 824-6304

Participating Towns:

Langrove, Londonderry, Peru, Weston, Windham.

MAD RIVER SOLID WASTE ALLIANCE

P.O. Box 210
Waterbury Center, VT 05677
(802) 244-7373
Fax: (802) 244-7570
Email: malterport@aol.com

Participating Towns:

Duxbury, Fayston, Moretown, Waitsfield, Warren, Waterbury.

NORTHEAST KINGDOM WASTE MANAGEMENT DISTRICT

P.O. Box 1075
Lyndonville, VT 05851
(802) 626-3532 or 800-734-4602
Fax: 626-3519
email: progmgr@nekwmd.org

Participating Towns:

Averill, Averys Gore, Barnet, Bloomfield, Brighton, Brunswick, Concord, Danville, East Haven, Ferdinand, Granby, Groton, Guildhall, Holland, Lewis, Lunenburg, Lyndon, Maidstone, Morgan, Newark, Peacham, Ryegate, Sheffield, Stannard, Victory, Waterford, Warren Gore, Warners Grant, Westmore, Wheelock.

NORTHWEST VERMONT SOLID WASTE MANAGEMENT DISTRICT

10-12 Kingman Street
P.O. Box 1547
St. Albans, VT 05478
(802) 524-5986
Fax: 524-5987
email: nswsdps@adelphia.net

Participating Towns:

Alburg, Bakersfield, Berkshire, Enosburg, Fairfield, Fletcher, Isle LaMotte, Montgomery, Richford, St. Albans City, Sheldon, South Hero.

RUTLAND COUNTY SOLID WASTE DISTRICT

2 Green Hill Lane
Rutland, VT 05701-5915
(802) 775-7209
Fax: 773-5796
E-mail: rcswd@rcswd.com
Recycling Hot Line: 773-4083

Participating Towns:

Brandon, Castleton, Clarendon, Danby, Hubbardton, Ira, Mendon, Mt. Tabor, Pittsford, Poultney, Proctor, Rutland City, Sherburne, Wallingford, Wells, West Rutland.

SOUTHERN WINDSOR/WINDHAM COUNTY SOLID WASTE MANAGEMENT DISTRICT

c/o NH/VT Solid Waste Project
130 Pleasant Street suite #3
Claremont, NH 03743
(603) 543-1201
Fax: (603) 542-5727

Participating Towns:

Andover, Baltimore, Cavendish, Chester, Grafton, Ludlow, Plymouth, Reading, Rockingham, Springfield, Weathersfield, Westminster, West Windsor, Windsor.

WHITE RIVER ALLIANCE

c/o Del Cloud
Bethel Town Manager
RR 1 Box 335
Bethel, VT 05032
(802) 234-9340
Fax: (802) 234-6840

Participating Towns:

Barnard, Bethel, Hancock, Pittsfield, Rochester, Royalton, Stockbridge.

WINDHAM SOLID WASTE MANAGEMENT DISTRICT

327 Old Ferry Road
Brattleboro, VT 05301
(802) 257-0272
Fax: 257-5122

Participating Towns:

Brattleboro, Brookline, Dover, Dummerston, Guilford, Halifax, Jamaica, Marlboro, Newfane, Putney, Readsboro, Townshend, Vernon, Whitingham, Wilmington.

OTHER CONTACTS

Towns not listed in any of these Solid Waste Districts or Alliances should contact their town clerk, town offices or the Vermont Agency of Natural Resources for more information on proper disposal of Hazardous Waste.

APPENDIX B

MERCURY CLEAN-UP PROFESSIONALS

The following is a partial list of companies that offer remediation (clean-ups/elimination, etc.) concerning air quality related situations. This list is not a recommendation or endorsement by the Vermont Agency of Natural Resources.

Key: L=liquid mercury
M=microbial (mold, mildew, fungus, and/or bacterial)
O=odors (post fire, etc.)
C=chemical
F=fuel

Clean Harbors Env. Services, Inc.

Offices also near Concord, NH and Boston, MA
(1-800-OILTANK)
32 Basik Road
Glenmount, NY 12077
(518) 434-0149
Key- (M,O,L,C,F)

Environmental Products & Service

2 Flynn Avenue
Burlington, VT 05401
(802) 862-1212 or (1-800-THETANK)
FAX-(802)860-7445
(24 hr, 7/day/upc full cleanup response)
Key- (L,C,F,M)

Seacoast Ocean Services/SOS

36 Custom House Wharf
Portland, Maine 04101
(800) 339-2111 or (207) 774-2111
FAX (207) 774-7240
Email: servoprovtt@aow.com
Key- (M,O,L,C,F)

Twin State Environmental Corp.

34 Roosevelt Highway
Colchester, VT 05446
(802) 654-8663
FAX (802) 654-8667
Email: tsec@together.net
Key- (L,C,F)

APPENDIX C

HAZARDOUS WASTE TRANSPORTERS

The following is a partial list of companies that offer hazardous waste transportation. This list is not a recommendation or endorsement by the Vermont Agency of Natural Resources.

APTUS Inc.

21750 Cedar Avenue
P.O. Box 550
Lakeville, MN 55044
Contact: Bruce Burniece (612) 469-3475

Clean Harbors Environmental Services

35 Commerce Street #9
Williston, VT 05495
Contact: Cathy McNamara (802) 651-0558

ENPRO Services Inc.

12 Mulliken Way
Newburyport, MA 01950
Contact: Larry Bouchard (978) 465-1595

Environmental Hazards Management Inc.

P.O. Box 785
Williston, VT 05495
Contact: Ken Morton (802) 862-4537

Environmental Products & Services of VT

2 Flynn Avenue
Burlington, VT 05401
Contact: Donald Melander (802) 862-1212

Heritage Environmental Services

2 Avenue D
Williston, VT 05495
Contact: Kendra Demarest (802) 860-1200

North Country Environmental Services

11 Mill Street
Barre, VT 05461
Contact: David Barchard (802) 479-5299

Safety Kleen Corp.

221 Sutton Street
North Andover, MA 01845
Contact: Brenda Leonardo

Total Waste Management

142 River Road
Newington, NH 03801
Contact: Kevin Schmit (800) 345-4525

Triumvirate Environmental Inc.

P.O. Box 136
Boston, MA 02143-0003
Contact: Jeff Plotts (800) 966-9282

APPENDIX D

MERCURY RECYCLERS

The following is a partial list of mercury recyclers that accept all mercury-added products. This list is not a recommendation or endorsement by the Vermont Agency of Natural Resources.

Adrow Chemical

2 Lines Ave.
Wanaque, NJ 07465
Phone: (201) 839-2372
Contact: Bill Delaney or Frank Bindhammer

Bethlehem Apparatus

890 Front St., P.O. Box Y
Hellertown, PA 18055
Phone: (610) 838-7034
Contact: John Boyle

Mercury Refining Co.

1218 Central Avenue
Albany, NY 12205
Phone: (518) 459-0820
Contact: Aaron Mars

Advance Env. Recycling Corp.

2591 Mitchell Ave.
Allentown, PA 18103
Phone: (800) 554-2372

Environmental Enterprises, Inc.

10163 Cincinnati-Dayton Rd.
Cincinnati, OH 45241
Phone: (800) 722-2818

Mercury Waste Solutions, Inc.

21211 Durand Avenue
Union Grove, WI 53182
Phone: (800) 741-3343
Contact: Zach Unruh



Environmental Fact Sheet

Vermont Department of
Environmental Conservation
103 South Main Street
Waterbury, VT 05671

<http://www.anr.state.vt.us/dec/dec.htm>

VTDEC Publication #EA-1001

November, 2000

Fluorescent Lamps: Handling and Disposal Guidelines

Fluorescent and HID Lamps:

Fluorescent and HID lamps contain mercury, a highly toxic heavy metal. When lamps are broken or thrown in the trash, mercury is released to the environment. Even the small amount of mercury-laden phosphor powder contained in lamps can damage our lakes and streams and poison fish and wildlife. It is due to this toxicity of the mercury contained in lamps, that there are restrictions (limits) on their disposal.

In Vermont, the following types of lamps should not be placed in the trash:

Fluorescent Lamps

- full size fluorescents
- compact fluorescents

High Intensity Discharge (HID) Lamps

- mercury vapor lamps
- metal halide lamps
- sodium lamps



Why Use Fluorescent and HID Lamps?

Using energy-efficient lighting makes good sense because:

- Fluorescent and HID lamps last longer
- Use less electricity than incandescent lamps and therefore:
 - Cost less to run
 - Result in less air pollution emitted from coal-burning power plants.

Vermont Law Requires:

- Proper labeling of mercury-added products.
- Towns and Solid Waste Districts to implement a program to collect mercury-added consumer products and to inform the public about them.
- Proper disposal.

General Recycling Guide for Fluorescent Lamps:

Here are a few precautions to take with Fluorescent and HID lamps after they have burned out:

- Do not break or crush lamps because mercury will be released.
- To avoid breaking the lamps, package them carefully when storing and transporting them. **DO NOT TAPE THEM TOGETHER!**
- Contact your local Town Manager or Solid Waste District (listed on the back of sheet) or the Agency of Natural Resources for information on the recycling program for Fluorescent and HID lamps in your area.
- If lamps are accidentally broken, follow the clean-up procedure below.

Lamp Breakage Clean-up Procedure

- 1 Keep all people and pets away from breakage area so that mercury powder is not tracked into other areas.
- 2 Keep the area well ventilated.
- 3 Assemble the necessary supplies before cleaning up: Latex gloves, tweezers, tape, and a puncture resistant container.
- 4 Using the latex gloves, carefully pick up any broken glass and place in a puncture resistant container. Tweezers may be needed to safely pick up broken glass. Tape can also be used to pick up any remaining small pieces of glass and powder residue still located on the spill surface. **DO NOT VACUUM.**
- 5 After clean-up is complete, place the contaminated clean-up equipment along with any other material that came in contact with the mercury powder into the puncture resistant container or a sealable plastic bag.
- 6 Contact your local Town Manager, Solid Waste District or the Agency of Natural Resources for waste management options.

For additional information contact: Environmental Assistance Division tele: 802-241-3589 fax: 802-241-3273
e-mail: ead@dec.anr.state.vt.us
web site: <http://www.anr.state.vt.us/dec/ead/eadhome.htm>

Fluorescent Lamp Management Q&A for Businesses & Municipalities

Should I crush my lamps?

No, crushing mercury-containing lamps may pose health and environmental risks when mercury vapors are released. Lamps should be stored in ways that avoid breakage.

How should I store mercury-containing lamps?

- ◊ Place used lamps in packaging functionally equivalent to that used to ship new lamps.
- ◊ Seal full packages with tape (**Do not tape lamps together**).
- ◊ Label packages with any one of the following phrases:
 - “Waste Mercury-Containing Lamp(s)”
 - “Used Mercury-Containing Lamp(s)”
 - “Universal Waste Mercury-Containing Lamp(s)”
- ◊ Store packages of lamps no more than five (5) feet high.
- ◊ Store packages for no more than one year.
- ◊ Store packages of waste mercury-containing lamps in a storage area identified by a sign that is clearly visible and has a label that includes the words: “Waste Mercury-Containing Lamps”.

What if a mercury-containing lamp breaks?

Once a lamp is broken, it is considered a hazardous waste and should not be thrown in the trash. First allow the area to ventilate for 15 minutes. Then transfer any damaged or broken mercury-containing lamps and residue to a closed compatible container labeled “Hazardous Waste” (with a description of the contents). Once properly contained and labeled, the broken lamps and residue should be stored on an impervious surface within a structure that sheds rain and snow.

How should we train workers who handle waste lamps?

All employees who handle or manage mercury-containing products shall be informed of proper handling and emergency procedures.

Do I need any permits for transporting my own waste fluorescent and HID lamps?

No, only commercial haulers of waste lamps need to get a waste transporter’s permit or certification.

What are the disposal options for mercury-containing lamps?

- ① Recycling through a Municipal or Solid Waste District Household Hazardous Waste collection program,
- ② Direct shipment to a lamp recycler or,
- ③ Shipment through a hazardous waste transporter.

Where can I get additional information?

Additional information can be found by:

- ◊ Contacting your local Town Manager (if not in a Solid Waste District),
- ◊ Contacting your local Solid Waste District (*see the list at right*)
- ◊ Contacting the Agency of Natural Resources:
 - Waste Management Division (802) 241-3888
 - Environmental Assistance Division (802) 241-3589
- ◊ Accessing the following website <http://www.anr.state.vt.us/dec/waste.htm>
- ◊ Reviewing Subchapter 9 of the Vermont Hazardous Waste Regulations (*accessible through the above website*)

Vermont Solid Waste Districts

ADDISON COUNTY
SOLID WASTE DISTRICT
(802) 388-2333

BENNINGTON REGIONAL
PLANNING COMMISSION
(802) 375-2576

CENTRAL VERMONT
SOLID WASTE DISTRICT
1-800-730-9475 OR (802) 229-9383

CHITTENDEN
SOLID WASTE DISTRICT
(802) 872-8111

GREATER UPPER VALLEY
SOLID WASTE DISTRICT
(802) 296-3688

LAMOILLE REGIONAL
SOLID WASTE DISTRICT
(802) 888-7317

MAD RIVER
SOLID WASTE ALLIANCE
(802) 244-7373

NORTHEAST KINGDOM
WASTE MANAGEMENT DISTRICT
1-800-734-4602 OR (802) 626-3532

NORTHWEST VERMONT
SOLID WASTE DISTRICT
(802) 524-5986

SOUTHERN WINDSOR/
WINDHAM COUNTY
SOLID WASTE MGMT DISTRICT
(603) 543-1201 OR (802) 885-5827

RUTLAND COUNTY
SOLID WASTE DISTRICT
(802) 775-7209 OR 802-773-4083

RUTLAND NON-DISTRICT
TOWNS JMSC/SWAC
(802) 235-2710

WHITE RIVER
ALLIANCE
(802) 234-9340

WINDHAM SOLID
WASTE DISTRICT
(802) 257-0272



Environmental Fact Sheet

Vermont Department of
Environmental Conservation
103 South Main Street
Waterbury, VT 05671

<http://www.anr.state.vt.us/dec/dec.htm>

VTDEC Publication #EA-1002

July, 2001

Waste Mercury-Added Devices: Handling and Disposal Guidelines

Thermometers, Silent Switches and Temperature Probes

In addition to thermometers, mercury has been used for many years in electrical products. A moving drop of mercury is used to open or close electrical circuits in devices like thermostats, silent wall switches, sump pumps, and the tilt switches in automobiles, chest freezers, washing machines, and space heaters. Mercury is a naturally occurring heavy metal which at room temperature takes the form of a silvery liquid. When a mercury-containing device is broken or thrown in the trash, mercury is released to the environment. Even a small amount of mercury can damage our lakes and streams and poison fish and wildlife. It is because of mercury's toxicity that restrictions (limits) have been placed on how and where mercury-added products are disposed.



Recognizing a Mercury-Added Device Is Not Always Easy

Although it is easy to see the silvery mercury in the bulb of a thermometer or the glass tilt switch of a home thermostat, most mercury containing devices enclose their mercury-added switches inside rubber, plastic or metal coverings. Also, not all electrical switches and temperature probes use mercury to function. Your Town Clerk, Town Manager, Solid Waste District (listed on the back of this sheet) and the Agency of Natural Resources has more information about which products have mercury in them and about the recycling programs for mercury-added devices in your area. (Also, see our Environmental Fact Sheet on Waste Mercury-Containing Lamps)

Vermont Law Requires...

- ☞ Proper labeling of mercury-added products.
- ☞ Towns and Solid Waste Districts to offer programs to collect mercury-added consumer products and to inform the public about them.
- ☞ Proper disposal, **NOT IN THE TRASH!**

General Recycling Guidelines

- ☞ Do not break, crush or take apart a mercury-added switch or device because mercury will be released.
- ☞ To avoid breaking the devices, package them carefully in individually sealed plastic bags placed inside larger sealable containers before storing or transporting them.
- ☞ Contact your Town Clerk, local Solid Waste District (listed on the back of this sheet) or the Agency of Natural Resources for information about recycling programs for mercury-added devices in your area.
- ☞ Contact local heating and air conditioning contractors or wholesalers about free thermostat take-back available through the Thermostat Recycling Corporation.
- ☞ If a mercury-added device is accidentally broken, use the following clean-up procedure.

Mercury Spill Cleanup Procedure

DO NOT SWEEP OR VACUUM MERCURY!

- 1 Keep all people and pets away from the breakage area so that mercury is not tracked elsewhere.
- 2 Keep the area well ventilated by opening windows and shutting off the heat or air conditioning.
- 3 Collect the necessary supplies before cleaning up: latex gloves, stiff paper or cards, paper towels or tissues, wide masking or duct tape, a leak-tight plastic bag or sealable container, a small plastic scoop or eye dropper.
- 4 Wearing the gloves, carefully pick up any broken glass or pieces of the device. Place on a paper towel or tissue. Wrap or fold the paper towel and place it in a leak-tight plastic bag or sealable container.
- 5 Working from the edge of the spill towards the center, use a card or stiff paper to push small beads of mercury into larger droplets. Push the droplets into a plastic scoop or pick them up with an eye dropper. Place the mercury in a leak-tight plastic bag or sealable container.
- 6 Use the sticky side of masking or duct tape to pick up remaining bits of glass or mercury beads. Put the tape, debris, gloves and cleanup equipment in a leak-tight plastic bag or sealable container.
- 7 Contact your Town Clerk, Solid Waste District or the Agency of Natural Resources about how to dispose of mercury spill cleanup materials.

Mercury-Added Device Management Q & A for Businesses and Municipalities

How should I handle mercury-added devices?

Mercury-added switches and devices are often removable components found inside much larger appliances. Once the switch or component has been removed from the larger product, the component should not be disassembled further. If need be, it should be stored in an individually sealed plastic bag placed inside a larger sealable container to avoid breakage. Direct exposure to mercury metal may pose health and environmental risks when mercury vapors are released.

Is every waste mercury-added product a hazardous waste?

When taken by itself, a mercury-added switch would exhibit the hazardous waste characteristic of toxicity for mercury. However, the hazardous waste regulations which apply to the proper handling and disposal of a mercury-added component do not automatically extend to the larger products containing them. For example, a mercury-added hood or trunk light switch does not turn the whole car into a hazardous waste.

May waste mercury-added products or devices be handled as something other than a hazardous waste?

Yes. Both Vermont and federal hazardous waste regulations already contain provisions to simplify the handling and recycling of waste mercury-added thermostats and lamps. These are called "Universal Wastes". Under current Vermont Waste Management Division policy, the terms of these provisions have been extended to all fabricated mercury-added products, switches, and devices that are not presently listed as so-called "Universal Wastes".

What if a mercury-added device breaks?

At a minimum, the device, the released mercury and cleanup debris should be sealed in a plastic bag and transferred to a closed compatible container labeled "Hazardous Waste" (with a description of the contents) and managed as a hazardous waste.

What should we tell workers who handle waste mercury-added products?

All employees who handle or manage mercury-added products should be informed of the proper handling and emergency procedures for these products and for mercury.

What are the disposal options for mercury-added devices?

- 1 Recycling through a Municipal or Solid Waste District's Household Hazardous Waste collection program.
- 2 Thermostats only Recycling by heating, ventilation and air conditioning wholesalers participating in the free thermostat take-back sponsored by the Thermostat Recycling Corporation.
- 3 Direct shipment as "Universal Waste" to a mercury recycling facility.
- 4 Shipment through a hazardous waste transporter to a proper destination facility.

Where can I get additional information?

- ☞ Contact your Town Clerk or Town Manager (if not in a Solid Waste District)
- ☞ Contact your Solid Waste District (see list to the right or the Agency web site below)
- ☞ Contact the Vermont Agency of Natural Resources:

- Waste Management Division (802) 241-3888 (Hazardous/Universal Wastes)
- Environmental Assistance Division (802) 241-3589 (Mercury-Added Products) or, on the web at: www.anr.state.vt.us/dec/waste.htm or www.mercvt.org

- ☞ Also, see our "Waste Mercury Containing Lamps" and "Universal Waste" Fact Sheets
- ☞ Review the Vermont Hazardous Waste Management Regulations in Subchapter 9: Universal Waste Management Standards. (also available on the Agency of Natural Resources website above)

Vermont Solid Waste Districts

ADDISON COUNTY
SOLID WASTE DISTRICT
(802) 388-2333

BENNINGTON REGIONAL
PLANNING COMMISSION
(802) 375-2576

CENTRAL VERMONT
SOLID WASTE DISTRICT
1-800-730-9475 OR (802) 229-9383

CHITTENDEN
SOLID WASTE DISTRICT
(802) 872-8111

GREATER UPPER VALLEY
SOLID WASTE DISTRICT
(802) 296-3688

LAMOILLE REGIONAL
SOLID WASTE DISTRICT
(802) 888-7317

MAD RIVER
SOLID WASTE ALLIANCE
(802) 244-7373

NORTHEAST KINGDOM
WASTE MANAGEMENT DISTRICT
1-800-734-4602 OR (802) 626-3532

NORTHWEST VERMONT
SOLID WASTE DISTRICT
(802) 524-5986

SOUTHERN WINDSOR/
WINDHAM COUNTY
SOLID WASTE MGMT DISTRICT
(603) 543-1201 OR (802) 885-5827

RUTLAND COUNTY
SOLID WASTE DISTRICT
(802) 775-7209 OR 802-773-4083

RUTLAND NON-DISTRICT
TOWNS JMISC/SWAC
(802) 235-2710

WHITE RIVER
ALLIANCE
(802) 234-9340

WINDHAM SOLID
WASTE DISTRICT
(802) 257-0272

For more information contact:

Environmental
Assistance
Division

tele: 802-241-3589 fax: 802-241-3273

e-mail: ead@dec.anr.state.vt.us

www.anr.state.vt.us/dec/ead/eadhome.htm

REFERENCES

1. Discussion Paper: Management of Hard to Handle Wastes in Vermont. Vermont Agency of Natural Resources. May 1998.
2. Managing Problem Materials Generated by Discarded Appliances and Vehicles. Report to Northeast Waste Management Officials' Association. Prepared by DPRA Incorporated. September 1994.
3. Fact Sheet: Mercury Applications in Major Appliances and Heating/Cooling Systems. Minnesota Office of Environmental Compliance. April 13, 1998.
4. Info Bulletin #8: Mercury in Home Appliances. Appliance Recycling Information Center. August 1998.
5. Fact Sheet: Did You Know that the Vermont Legislature has Banned Some Wastes from Landfills? Vermont Agency of Natural Resources. October 1992.
6. Fact Sheet: What if I Spill Mercury? Purdue Research Foundation. 1996.
7. Toxics in Vehicles: Mercury. Ecology Center Great Lakes United University of Tennessee Center for Clean Products and Clean Technologies. January 2001.
8. Getting the Mercury Out of Vermont's Environment. Vermont's Advisory Committee on Mercury Pollution. January 2001.
9. What Devices Contain Mercury? Purdue Research Foundation. 1996.
10. Hazardous Waste Management Regulations. State of Vermont Agency of Natural Resources. March 28, 2000.
11. Factsheet: Fluorescent Lamps: Handling and Disposal Guidelines. State of Vermont Agency of Natural Resources. November 2000.
12. Factsheet: Waste Mercury-Containing Switches and Devices: Handling and Disposal Guidelines. Agency of Natural Resources. June 2001.
13. Mercury Factsheet: What is Mercury? Why be concerned? Indiana Office of Pollution Prevention and Technical Assistance. May 2000.

Appendix E

PCB Regulations



CANADA

CONSOLIDATION

CODIFICATION

PCB Regulations

Règlement sur les BPC

SOR/2008-273

DORS/2008-273

Current to June 17, 2015

À jour au 17 juin 2015

Last amended on January 1, 2015

Dernière modification le 1 janvier 2015

Published by the Minister of Justice at the following address:
<http://laws-lois.justice.gc.ca>

Publié par le ministre de la Justice à l'adresse suivante :
<http://lois-laws.justice.gc.ca>

OFFICIAL STATUS
OF CONSOLIDATIONS

CARACTÈRE OFFICIEL
DES CODIFICATIONS

Subsections 31(1) and (3) of the *Legislation Revision and Consolidation Act*, in force on June 1, 2009, provide as follows:

Les paragraphes 31(1) et (3) de la *Loi sur la révision et la codification des textes législatifs*, en vigueur le 1^{er} juin 2009, prévoient ce qui suit :

Published
consolidation is
evidence

31. (1) Every copy of a consolidated statute or consolidated regulation published by the Minister under this Act in either print or electronic form is evidence of that statute or regulation and of its contents and every copy purporting to be published by the Minister is deemed to be so published, unless the contrary is shown.

31. (1) Tout exemplaire d'une loi codifiée ou d'un règlement codifié, publié par le ministre en vertu de la présente loi sur support papier ou sur support électronique, fait foi de cette loi ou de ce règlement et de son contenu. Tout exemplaire donné comme publié par le ministre est réputé avoir été ainsi publié, sauf preuve contraire.

Codifications
comme élément
de preuve

...

[...]

Inconsistencies
in regulations

(3) In the event of an inconsistency between a consolidated regulation published by the Minister under this Act and the original regulation or a subsequent amendment as registered by the Clerk of the Privy Council under the *Statutory Instruments Act*, the original regulation or amendment prevails to the extent of the inconsistency.

(3) Les dispositions du règlement d'origine avec ses modifications subséquentes enregistrées par le greffier du Conseil privé en vertu de la *Loi sur les textes réglementaires* l'emportent sur les dispositions incompatibles du règlement codifié publié par le ministre en vertu de la présente loi.

Incompatibilité
— règlements

NOTE

This consolidation is current to June 17, 2015. The last amendments came into force on January 1, 2015. Any amendments that were not in force as of June 17, 2015 are set out at the end of this document under the heading “Amendments Not in Force”.

NOTE

Cette codification est à jour au 17 juin 2015. Les dernières modifications sont entrées en vigueur le 1 janvier 2015. Toutes modifications qui n'étaient pas en vigueur au 17 juin 2015 sont énoncées à la fin de ce document sous le titre « Modifications non en vigueur ».

TABLE OF PROVISIONS

TABLE ANALYTIQUE

Section	Page	Article	Page
PCB Regulations		Règlement sur les BPC	
PART 1		PARTIE 1	
GENERAL	1	GÉNÉRALITÉS	1
1	1	1	1
2	3	2	3
3	3	3	3
4	4	4	4
PART 2		PARTIE 2	
PROHIBITIONS AND PERMITTED ACTIVITIES	4	INTERDICTIONS ET ACTIVITÉS PERMISES	4
PROHIBITIONS	4	INTERDICTIONS	4
5	4	5	4
6	4	6	4
PERMITTED ACTIVITIES	5	ACTIVITÉS PERMISES	5
7	5	7	5
8	5	8	5
9	6	9	6
10	6	10	6
11	6	11	6
12	7	12	7
13	7	13	7
14	7	14	7
15	8	15	8
END-OF-USE DATES AND EXTENSION	9	UTILISATION — DATES LIMITES ET PROLONGATION	9
16	9	16	9
17	10	17	10
PART 3		PARTIE 3	
STORAGE	14	STOCKAGE	14
18	14	18	14
19	15	19	15
20	16	20	16
21	17	21	17
22	17	22	17

Section	Page	Article	Page		
23	PCBs or products containing PCBs stored on September 5, 2008	18	23	BPC et produits qui en contiennent stockés le 5 septembre 2008	18
24	PCB storage site	19	24	Dépôt de BPC	19
25	Storage requirements	19	25	Exigences relatives au stockage	19
26	Access to PCB storage site	23	26	Accès au dépôt de BPC	23
27	Inspection and maintenance of a PCB storage site	23	27	Inspection et entretien des dépôts de BPC	23
28	Fire protection and emergency procedures	24	28	Protection contre les incendies et mesures d'urgence	24
	PART 4			PARTIE 4	
	LABELLING, REPORTS AND RECORDS	26		ÉTIQUETAGE, RAPPORTS ET REGISTRES	26
	LABELLING	26		ÉTIQUETAGE	26
29	Equipment and liquids used for their servicing	26	29	Pièces d'équipement et liquides pour leur entretien	26
30	Cables and pipelines	27	30	Câbles et pipelines	27
31	A facility other than transfer site or destruction facility	28	31	Installation autre qu'un centre de transfert ou de destruction	28
32	Retention of labels	29	32	Conservation des étiquettes	29
	REPORTS	29		RAPPORTS	29
33	End of use of equipment and liquids — 2009	29	33	Date de fin d'utilisation des pièces d'équipement et des liquides — 2009	29
34	Research	33	34	Recherches	33
35	Colouring pigment	33	35	Pigments pour la coloration	33
36	Solid products containing PCBs	34	36	Produits solides qui contiennent des BPC	34
37	Stored PCBs or products — PCB concentration of 50 mg/kg or more	35	37	BPC ou produits stockés — concentration de BPC de 50 mg/kg ou plus	35
38	Stored PCBs or products — transfer site or destruction facility	36	38	BPC ou produits stockés — Centre de transfert ou de destruction	36
39	Date of submission of report	37	39	Date de présentation des rapports	37
40	Release into the environment	38	40	Rejets dans l'environnement	38
41	Retention	39	41	Conservation	39
42	Method of submission	39	42	Méthode de présentation	39
	RECORD KEEPING	39		TENUE DE REGISTRES	39
43	Records for permitted activities	39	43	Registres des activités permises	39
44	Inspection record	40	44	Registres d'inspections	40
45	Retention of records	40	45	Conservation des registres	40

Section	Page	Article	Page
48	Coming into force	48	Entrée en vigueur

PART 5

REPEALS AND COMING INTO FORCE

REPEALS

COMING INTO FORCE

PARTIE 5

ABROGATIONS ET ENTRÉE EN VIGUEUR

ABROGATION

ENTRÉE EN VIGUEUR

Registration
SOR/2008-273 September 5, 2008

CANADIAN ENVIRONMENTAL PROTECTION ACT,
1999

PCB Regulations

P.C. 2008-1659 September 5, 2008

Whereas, pursuant to subsection 332(1)^a of the *Canadian Environmental Protection Act, 1999*^b, the Minister of the Environment published in the *Canada Gazette*, Part I, November 4, 2006, a copy of the proposed *PCB Regulations*, substantially in the annexed form, and persons were given an opportunity to file comments with respect to the proposed Regulations or to file a notice of objection requesting that a board of review be established and stating the reasons for the objection;

Whereas, pursuant to subsection 93(3) of that Act, the National Advisory Committee has been given an opportunity to provide its advice under section 6^c of that Act;

And whereas, in the opinion of the Governor in Council, pursuant to subsection 93(4) of that Act, the proposed Regulations do not regulate an aspect of a substance that is regulated by or under any other Act of Parliament in a manner that provides, in the opinion of the Governor in Council, sufficient protection to the environment and human health;

Therefore, Her Excellency the Governor General in Council, on the recommendation of the Minister of the Environment and the Minister of Health, pursuant to subsection 93(1) and section 97 of the *Canadian Environmental Protection Act, 1999*^b, hereby makes the annexed *PCB Regulations*.

Enregistrement
DORS/2008-273 Le 5 septembre 2008

LOI CANADIENNE SUR LA PROTECTION DE
L'ENVIRONNEMENT (1999)

Règlement sur les BPC

C.P. 2008-1659 Le 5 septembre 2008

Attendu que, conformément au paragraphe 332(1)^a de la *Loi canadienne sur la protection de l'environnement (1999)*^b, le ministre de l'Environnement a fait publier dans la *Gazette du Canada* Partie I, le 4 novembre 2006, le projet de règlement intitulé *Règlement sur les BPC*, conforme en substance au texte ci-après, et que les intéressés ont ainsi eu la possibilité de présenter leurs observations à cet égard ou un avis d'opposition motivé demandant la constitution d'une commission de révision;

Attendu que, conformément au paragraphe 93(3) de cette loi, le comité consultatif national s'est vu accorder la possibilité de formuler ses conseils dans le cadre de l'article 6^c de celle-ci;

Attendu que la gouverneure en conseil est d'avis que, aux termes du paragraphe 93(4) de cette loi, le projet de règlement ne vise pas un point déjà réglementé sous le régime d'une autre loi fédérale de manière à offrir une protection suffisante pour l'environnement et la santé humaine,

À ces causes, sur recommandation du ministre de l'Environnement et du ministre de la Santé et en vertu du paragraphe 93(1) et de l'article 97 de la *Loi canadienne sur la protection de l'environnement (1999)*^b, Son Excellence la Gouverneure générale en conseil prend le *Règlement sur les BPC*, ci-après.

^a S.C. 2004, c. 15, s. 31

^b S.C. 1999, c. 33

^c S.C. 2002, c. 7, s. 124

^a L.C. 2004, ch. 15, art. 31

^b L.C. 1999, ch. 33

^c L.C. 2002, ch. 7, art. 124

PCB REGULATIONS

PART 1

GENERAL

Definitions **1.** (1) The following definitions apply in these Regulations.

“Act”
«Loi» “Act” means the *Canadian Environmental Protection Act, 1999*.

“authorized facility”
«installation agréée» “authorized facility” means a facility, including a transfer site, that is authorized by the authorities of the jurisdiction in which it is located to process PCBs or products containing PCBs or to conduct laboratory analysis or research with PCBs or products containing PCBs.

“National Fire Code”
«Code national de prévention des incendies» “National Fire Code” means the National Fire Code of Canada 2005, NRCC No. 47667, issued by the Canadian Commission on Building and Fire Codes, National Research Council of Canada, as amended from time to time.

“PCB”
«BPC» “PCB” means any chlorobiphenyl described in item 1 of the List of Toxic Substances in Schedule 1 to the Act.

“process” [Repealed, SOR/2011-301, s. 3]

“product” [Repealed, SOR/2011-301, s. 3]

Concentration — several matrices (2) For the purposes of these Regulations, if a solid or a liquid containing PCBs is composed of several matrices, the concentration of PCBs is based on the mass of the matrix in which the PCBs are located.

Concentration and quantity (3) For the purposes of these Regulations, the concentration and quantity of PCBs shall be determined by a laboratory

RÈGLEMENT SUR LES BPC

PARTIE 1

GÉNÉRALITÉS

1. (1) Les définitions qui suivent s’appliquent au présent règlement.

«BPC» Tout biphényle chloré visé à l’article 1 de la liste des substances toxiques de l’annexe 1 de la Loi.

«Code national de prévention des incendies» Le *Code national de prévention des incendies — Canada 2005*, CNRC 47667F, avec ses modifications successives, publié par la Commission canadienne des codes du bâtiment et de prévention des incendies du Conseil national de recherches du Canada.

«installation agréée» Installation — notamment un centre de transfert — qui est autorisée par les autorités de la province ou du territoire où elle est située à transformer des BPC ou des produits qui en contiennent, ou à les utiliser pour des analyses de laboratoire ou des recherches.

«Loi» La *Loi canadienne sur la protection de l’environnement (1999)*.

«produit» [Abrogée, DORS/2011-301, art. 3]

«transformer» [Abrogée, DORS/2011-301, art. 3]

(2) Pour l’application du présent règlement, lorsqu’un solide ou un liquide qui contient des BPC est composé de plusieurs matrices, la concentration de BPC est basée sur la masse de la matrice dans laquelle les BPC se trouvent.

(3) Pour l’application du présent règlement, la concentration et la quantité de BPC sont déterminées par un laboratoire qui est :

Définitions

«BPC»
“PCB”

«Code national de prévention des incendies»
“National Fire Code”

«installation agréée»
“authorized facility”

«Loi»
“Act”

Concentration — plusieurs matrices

Concentration et quantité

(a) that is accredited by a Canadian accrediting body under the International Organization for Standardization standard ISO/IEC 17025:2005, entitled *General requirements for the competence of testing and calibration laboratories*, as amended from time to time, and the scope of whose accreditation includes the analytical method used to determine the concentration of PCBs in the matrix in which the PCBs are located; or

(b) that is accredited under the *Environment Quality Act*, R.S.Q., c. Q-2, as amended from time to time, and the scope of whose accreditation includes the analytical method used to determine the concentration of PCBs in the matrix in which the PCBs are located.

Sampling method

(4) For the purposes of these Regulations, other than section 13, the concentration of PCBs in a matrix is determined using a provincially, nationally or internationally recognized sampling method for PCBs in the matrix in which the PCBs are located.

Sampling method — bulk solid products

(5) For the purposes of section 13, the concentration of PCBs is determined using a sampling method for bulk solid products, which is set out in either federal or provincial legislation, as amended from time to time, or approved by the United States Environmental Protection Agency for compliance with the *Resource Conservation and Recovery Act* or with the regulations made under that Act, as amended from time to time.

SOR/2010-57, ss. 1(F), 20(F); SOR/2011-301, s. 3; SOR/2014-75, s. 1.

a) soit accrédité par un organisme canadien d'accréditation selon la norme ISO/CEI 17025:2005 de l'Organisation internationale de normalisation intitulée *Exigences générales concernant la compétence des laboratoires d'étalonnages et d'essais*, avec ses modifications successives, dont l'accréditation couvre la méthode d'analyse utilisée pour déterminer la concentration des BPC dans la matrice dans laquelle se trouvent les BPC;

b) soit accrédité conformément à la *Loi sur la qualité de l'environnement*, L.R.Q., ch. Q-2, avec ses modifications successives, dont l'accréditation couvre la méthode d'analyse utilisée pour déterminer la concentration des BPC dans la matrice dans laquelle se trouvent les BPC.

Méthode d'échantillonnage

(4) Pour l'application du présent règlement, sauf l'article 13, la concentration de BPC se trouvant dans une matrice est déterminée au moyen de toute méthode d'échantillonnage pour les BPC dans cette matrice qui est reconnue à l'échelle provinciale, nationale ou internationale.

Méthode d'échantillonnage — produits solides en vrac

(5) Pour l'application de l'article 13, la concentration de BPC est déterminée au moyen de toute méthode d'échantillonnage pour les produits solides en vrac qui est prévue par une loi ou un règlement fédéral ou provincial, avec ses modifications successives, ou qui est approuvée par la United States Environmental Protection Agency pour l'application de la loi des États-Unis intitulée *Resource Conservation and Recovery Act* ou de ses règlements avec leurs modifications successives.

DORS/2010-57, art. 1(F) et 20(F); DORS/2011-301, art. 3; DORS/2014-75, art. 1.

Application	<p>2. (1) These Regulations apply to PCBs and to any products containing PCBs.</p>	<p>2. (1) Le présent règlement s'applique aux BPC et à tout produit qui en contient.</p>	Application
Non-application	<p>(2) These Regulations do not apply to the following:</p> <p>(a) the export and import of PCBs that are hazardous waste or hazardous recyclable material within the meaning of the <i>Export and Import of Hazardous Waste and Hazardous Recyclable Material Regulations</i> or the export of PCBs that are waste within the meaning of the <i>PCB Waste Export Regulations, 1996</i>;</p> <p>(b) the sale, importation or advertising of liquids containing PCBs for use in microscopy, including immersion oils but not including refractive index oils, which is prohibited under section 5 of the <i>Canada Consumer Product Safety Act</i>; and</p> <p>(c) the offer for sale, sale and use of land contaminated with PCBs or with products containing PCBs.</p> <p>SOR/2014-75, s. 2.</p>	<p>(2) Il ne s'applique toutefois pas aux activités suivantes :</p> <p>a) l'exportation et l'importation de BPC qui sont des déchets dangereux ou des matières recyclables dangereuses au sens du <i>Règlement sur l'exportation et l'importation de déchets dangereux et de matières recyclables dangereuses</i> et l'exportation de déchets contenant des BPC au sens du <i>Règlement sur l'exportation de déchets contenant des BPC (1996)</i>;</p> <p>b) la vente, l'importation ou la publicité des liquides pour usage en microscopie qui contiennent des BPC — y compris les huiles à immersion mais à l'exclusion des huiles à indice de réfraction — interdites par l'article 5 de la <i>Loi canadienne sur la sécurité des produits de consommation</i>;</p> <p>c) la mise en vente, la vente et l'utilisation de terrains contaminés par des BPC ou des produits qui en contiennent.</p> <p>DORS/2014-75, art. 2.</p>	Exclusion
Sale of property	<p>3. Nothing in these Regulations shall be construed as preventing the sale of</p> <p>(a) personal property or movables that contain PCBs, or real property or immovables that have PCBs or products containing PCBs, and that form part of the sale of the whole or part of a business, including a manufacturing or a processing business;</p> <p>(b) real property or immovables that have products containing PCBs if the products continue to be used after the sale for the same purpose at the same</p>	<p>3. Le présent règlement n'a pas pour effet d'empêcher la vente des biens suivants :</p> <p>a) tout bien meuble ou personnel qui contient des BPC ou tout bien immeuble ou réel où se trouvent des BPC ou des produits qui en contiennent, lesquels biens sont compris dans la vente de tout ou partie d'une entreprise, y compris une entreprise de fabrication ou de transformation;</p> <p>b) tout bien immeuble ou réel dont font partie intégrante les produits qui contiennent des BPC qui s'y trouvent, si les produits continuent d'être utilisés</p>	Vente de biens

place and are an integral part of the property or immovable; or

(c) real property or immovables on which a PCB storage site is located.

Compliance

4. In addition to the persons who must comply with the requirements set out in these Regulations, a person who owns PCBs or products containing PCBs shall ensure that the requirements of these Regulations with respect to those PCBs or products are met.

aux mêmes fins et au même endroit après la vente;

c) tout bien immeuble ou réel où se trouve un dépôt de BPC.

Conformité

4. En plus des personnes auxquelles il incombe des obligations en vertu du présent règlement, le propriétaire de BPC ou de produits qui en contiennent veille à ce que les exigences du présent règlement concernant ces BPC ou produits soient remplies.

PART 2

PROHIBITIONS AND PERMITTED ACTIVITIES

PROHIBITIONS

Release into the environment

5. (1) No person shall release PCBs into the environment, other than from the equipment referred to in subsection (2), in a concentration of

(a) 2 mg/kg or more for a liquid containing PCBs; or

(b) 50 mg/kg or more for a solid containing PCBs.

Release from equipment

(2) No person shall release more than one gram of PCBs into the environment from equipment referred to in section 16 that is in use or from equipment in use for which an extension has been granted under section 17.

Prohibited activities

6. Except as provided in these Regulations, no person shall

PARTIE 2

INTERDICTIONS ET ACTIVITÉS PERMISES

INTERDICTIONS

Rejet dans l'environnement

5. (1) Il est interdit de rejeter dans l'environnement, autrement qu'à partir d'une pièce d'équipement visée au paragraphe (2), des BPC de l'une ou l'autre des concentrations suivantes :

a) dans le cas d'un liquide qui contient des BPC, une concentration égale ou supérieure à 2 mg/kg;

b) dans le cas d'un solide qui contient des BPC, une concentration égale ou supérieure à 50 mg/kg.

Rejet à partir d'une pièce d'équipement

(2) Il est interdit de rejeter plus d'un gramme de BPC dans l'environnement à partir d'une pièce d'équipement visée à l'article 16 qui est en usage ou d'une pièce d'équipement dont l'usage fait l'objet d'une prolongation en vertu de l'article 17 et qui est en usage.

Activités interdites

6. Sauf dans la mesure prévue par le présent règlement, il est interdit :

a) de fabriquer, d'exporter ou d'importer des BPC ou tout produit qui en

(a) manufacture, export or import PCBs or a product containing PCBs in a concentration of 2 mg/kg or more;

(b) offer for sale or sell PCBs or a product containing PCBs in a concentration of 50 mg/kg or more; or

(c) process or use PCBs or a product containing PCBs.

contient en une concentration égale ou supérieure à 2 mg/kg;

b) de mettre en vente ou de vendre des BPC ou tout produit qui en contient en une concentration égale ou supérieure à 50 mg/kg;

c) de transformer ou d'utiliser des BPC ou tout produit qui en contient.

PERMITTED ACTIVITIES

ACTIVITÉS PERMISES

Laboratory analysis

7. A person may manufacture, export, import, offer for sale, sell, process and use PCBs or products containing PCBs for the purpose of laboratory analysis if the analysis is conducted

(a) in an authorized facility that is authorized for that purpose; or

(b) in a facility that conforms to internationally recognized guidelines on best laboratory practices, if the authorities of the jurisdiction in which the facility is located do not have a mechanism in place to authorize the facility to conduct the analysis.

SOR/2010-57, s. 20(F).

7. Il est permis de fabriquer, d'exporter, d'importer, de mettre en vente, de vendre, de transformer et d'utiliser des BPC et des produits qui en contiennent pour des analyses de laboratoire, si celles-ci sont effectuées :

a) dans toute installation agréée à cette fin;

b) dans le cas où les autorités de la province ou du territoire où elle est située ne disposent d'aucun mécanisme l'autorisant à les effectuer, dans toute installation qui est conforme à des lignes directrices, reconnues à l'échelle internationale, sur les pratiques exemplaires en laboratoire.

DORS/2010-57, art. 20(F).

Analyses de laboratoire

Research

8. (1) A person may offer for sale or sell PCBs or products containing PCBs to be processed or used for the purpose of research to determine the effects of those PCBs or products on human health or on the environment, if the facility in which they are processed or used is

(a) an authorized facility that is authorized for that purpose; or

(b) a facility that conforms to internationally recognized guidelines on best laboratory practices, if the authorities of the jurisdiction in which the facility is

8. (1) Il est permis de mettre en vente ou de vendre des BPC ou des produits qui en contiennent pour qu'ils soient utilisés ou transformés à des fins de recherche visant à déterminer les effets des BPC ou des produits sur la santé humaine ou l'environnement, si l'installation où ils sont utilisés ou transformés se conforme à l'une ou l'autre des exigences suivantes :

a) elle est agréée à cette fin;

b) dans le cas où les autorités de la province ou du territoire où elle est située ne disposent d'aucun mécanisme l'auto-

Recherches

located do not have a mechanism in place to authorize the facility to conduct the research.

risant à effectuer des recherches, elle est conforme à des lignes directrices, reconnues à l'échelle internationale, sur les pratiques exemplaires en laboratoire.

Processing and use

(2) A person may process and use the PCBs or products containing PCBs for the purpose of the research referred to in subsection (1) at a facility that meets the requirement set out in paragraph (1)(a) or (b).

SOR/2010-57, s. 20(F).

(2) Il est permis de transformer et d'utiliser des BPC et des produits qui en contiennent pour effectuer les recherches visées au paragraphe (1) dans une installation qui se conforme à l'une ou l'autre des exigences prévues à ce paragraphe.

DORS/2010-57, art. 20(F).

Transformation et utilisation

Electrical capacitor

9. A person may offer for sale, sell and use an electrical capacitor containing PCBs if the electrical capacitor

(a) is an integral part of a consumer product;

(b) is fusion sealed; and

(c) would be rendered inoperable and irreparable if the PCBs were removed from it.

9. Il est permis de mettre en vente, de vendre et d'utiliser tout condensateur électrique qui contient des BPC, si les conditions suivantes sont réunies :

a) il fait partie intégrante d'un produit de consommation;

b) ses joints sont thermoscellés;

c) il ne fonctionnerait plus et serait irréparable si les BPC en étaient extraits.

Condensateurs électriques

Aircraft, ships, trains and other vehicles

10. A person may export, import, offer for sale, sell and use for transportation purposes aircraft, ships, trains and other vehicles that contain PCBs only in their communication, navigation or electronic control equipment or cables.

10. Il est permis d'exporter, d'importer, de mettre en vente, de vendre et d'utiliser pour le transport, tout aéronef, navire, train ou autre véhicule dont seuls l'équipement de communication, de navigation ou de commande électronique ou les câbles contiennent des BPC.

Aéronefs, navires, trains et autres véhicules

Colouring pigment

11. (1) A person may manufacture, export, import, offer for sale, sell, process and use a colouring pigment containing PCBs produced incidentally if the concentration of the PCBs is less than 50 mg/kg.

11. (1) Il est permis de fabriquer, d'exporter, d'importer, de mettre en vente, de vendre, de transformer et d'utiliser des pigments pour la coloration qui contiennent des BPC produits par inadvertance en une concentration inférieure à 50 mg/kg.

Pigments pour la coloration

Annual average concentration

(2) Despite subsection (1), the annual average concentration of PCBs produced incidentally in colouring pigment that a person may manufacture, export, import, offer for sale, sell, process and use shall not exceed 25 mg/kg.

SOR/2010-57, s. 2(F).

(2) Toutefois, la concentration moyenne annuelle de BPC produits par inadvertance dans les pigments pour la coloration fabriqués, exportés, importés, mis en vente, vendus, transformés et utilisés par toute personne ne peut dépasser 25 mg/kg.

DORS/2010-57, art. 2(F).

Moyenne annuelle maximale

Destruction	<p>12. A person may process PCBs or products containing PCBs for the purpose of destroying PCBs or recovering PCBs for the purpose of destroying them in an authorized facility that is authorized for that purpose.</p> <p>SOR/2010-57, s. 3(F).</p>	<p>12. Il est permis de transformer des BPC et des produits qui en contiennent pour les détruire dans une installation agréée à cette fin ou pour les récupérer afin de les détruire dans une telle installation.</p> <p>DORS/2010-57, art. 3(F).</p>	Destruction
Solid products	<p>13. (1) A person may manufacture solid products containing PCBs in a concentration of less than 50 mg/kg using bulk solid products containing PCBs in a concentration of less than 50 mg/kg, and may use those solid products.</p>	<p>13. (1) Il est permis de fabriquer des produits solides qui contiennent des BPC en une concentration inférieure à 50 mg/kg à partir de produits solides en vrac qui eux-mêmes contiennent des BPC en une concentration inférieure à 50 mg/kg et d'utiliser ces produits solides.</p>	Produits solides
Application	<p>(2) Subsection (1) only applies to the manufacture of the types of products that are manufactured before September 5, 2008.</p>	<p>(2) Le paragraphe (1) ne s'applique qu'aux types de produits qui sont fabriqués avant le 5 septembre 2008.</p>	Application
Exception	<p>(3) No person shall offer for sale or sell the products manufactured in accordance with subsection (1) unless the products are used in the course of a commercial or industrial activity.</p> <p>SOR/2010-57, s. 4.</p>	<p>(3) Il est interdit de mettre en vente ou de vendre des produits fabriqués conformément au paragraphe (1) pour tout usage en dehors d'une activité commerciale ou industrielle.</p> <p>DORS/2010-57, art. 4.</p>	Exception
Cables, pipelines, electrical capacitors and other equipment	<p>14. (1) A person may use the following products containing PCBs:</p> <p>(a) cables, if they remain in place on September 5, 2008;</p> <p>(b) pipelines that transport natural gas, petroleum or petroleum products and any associated equipment that is in contact with the natural gas, petroleum or petroleum products if the pipelines and the equipment remain in place on September 5, 2008;</p> <p>(c) fusion sealed capacitors if they are used in relation to communication equipment or electronic control equipment; and</p>	<p>14. (1) Il est permis d'utiliser les produits ci-après qui contiennent des BPC :</p> <p>a) tout câble, s'il demeure à l'endroit où il se trouvait le 5 septembre 2008;</p> <p>b) tout pipeline qui transporte du gaz naturel, du pétrole ou des produits pétroliers, ainsi que tout équipement connexe qui est en contact avec le gaz naturel, le pétrole ou les produits pétroliers, si le pipeline et l'équipement demeurent à l'endroit où ils se trouvaient le 5 septembre 2008;</p> <p>c) tout condensateur électrique dont les joints sont thermoscellés et qui est utilisé à des fins de communication ou de commande électronique;</p>	Câbles, pipelines, condensateurs électriques et pièces d'équipements

(d) the following equipment containing PCBs in a concentration of less than 50 mg/kg if the equipment is used for the purpose for which it was manufactured:

- (i) electrical capacitors, light ballasts, electrical transformers and their auxiliary electrical equipment, including pole-top electrical transformers and their pole-top auxiliary electrical equipment,
- (ii) electromagnets that are not used in the handling of food, feed or any additive to food or feed, and
- (iii) heat transfer equipment, hydraulic equipment, vapour diffusion pumps and bridge bearings.

Electrical capacitors

(2) A person may import fusion sealed capacitors containing PCBs for use in relation to communication tactical equipment or electronic control tactical equipment.

SOR/2010-57, ss. 5, 19.

Liquids for servicing — concentration less than 2 mg/kg

15. (1) A person may use liquids containing PCBs in a concentration of less than 2 mg/kg for the purpose of servicing equipment containing PCBs.

Liquids for servicing — concentration of 500 mg/kg or more

(2) A person may use liquids containing PCBs in a concentration of 500 mg/kg or more for the purpose of servicing equipment containing PCBs in a concentration of 500 mg/kg or more until December 31, 2009.

d) les pièces d'équipement ci-après qui contiennent des BPC en une concentration inférieure à 50 mg/kg et qui sont utilisées aux fins auxquelles elles étaient destinées lors de leur fabrication :

- (i) les condensateurs électriques, les ballasts de lampes, les transformateurs électriques et tout équipement électrique connexe, y compris les transformateurs sur poteaux et tout équipement électrique connexe sur poteaux,
- (ii) les électroaimants ne servant pas à la manutention des aliments destinés aux humains ou aux animaux, ou de tout additif à ces aliments,
- (iii) l'équipement caloporteur, l'équipement hydraulique, les pompes à diffusion de vapeur et les appareils d'appui de pont.

Condensateurs électriques

(2) Il est permis d'importer tout condensateur électrique qui contient des BPC et dont les joints sont thermoscellés pour qu'il soit utilisé à des fins de communication tactique ou de commande électronique tactique.

DORS/2010-57, art. 5 et 19.

Liquides pour entretien — concentration inférieure à 2 mg/kg

15. (1) Il est permis d'utiliser tout liquide qui contient des BPC en une concentration inférieure à 2 mg/kg pour l'entretien de toute pièce d'équipement qui contient des BPC.

Liquide pour entretien — concentration de 500 mg/kg ou plus

(2) Il est également permis, jusqu'au 31 décembre 2009, d'utiliser tout liquide qui contient des BPC en une concentration égale ou supérieure à 500 mg/kg pour l'entretien de toute pièce d'équipement qui elle-même contient des BPC en une concentration égale ou supérieure à 500 mg/kg.

END-OF-USE DATES AND EXTENSION

UTILISATION — DATES LIMITES ET
PROLONGATION

Equipment —
subparagraphs
14(1)(d)(i) to
(iii)

16. (1) Subject to subsections (2) and (2.1), a person may use the equipment referred to in subparagraphs 14(1)(d)(i) to (iii) until the following dates if the equipment is in use on September 5, 2008:

(a) in the case of equipment containing PCBs in a concentration of 500 mg/kg or more, December 31, 2009; and

(b) in the case of equipment containing PCBs in a concentration of at least 50 mg/kg but less than 500 mg/kg,

(i) December 31, 2009, if the equipment is located at a drinking water treatment plant or food or feed processing plant, in a child care facility, preschool, primary school, secondary school, hospital or senior citizens' care facility or on the property on which the plant or facility is located and within 100 m of it, and

(ii) December 31, 2025, if the equipment is located at any other place.

Light ballasts
and pole-top
electrical
transformers

(2) A person may use the following equipment containing PCBs in a concentration of 50 mg/kg or more until December 31, 2025, if the equipment is in use on September 5, 2008:

(a) light ballasts; and

(b) pole-top electrical transformers and their pole-top auxiliary electrical equipment.

Pièces
d'équipement
visées aux sous-
alinéas 14(1)(d)
(i) à (iii)

16. (1) Sous réserve des paragraphes (2) et (2.1), il est permis d'utiliser les pièces d'équipement visées aux sous-alinéas 14(1)(d)(i) à (iii) qui sont en usage le 5 septembre 2008 jusqu'aux dates suivantes :

a) si elles contiennent des BPC en une concentration égale ou supérieure à 500 mg/kg, jusqu'au 31 décembre 2009;

b) si elles contiennent des BPC en une concentration égale ou supérieure à 50 mg/kg mais inférieure à 500 mg/kg :

(i) jusqu'au 31 décembre 2009, si elles se trouvent dans une usine de traitement d'eau potable ou de transformation des aliments destinés aux humains ou aux animaux, dans une garderie, dans une école — de niveau préscolaire, primaire ou secondaire —, dans un hôpital ou dans une résidence pour personnes âgées ou sur le terrain d'un tel établissement, à 100 m ou moins de celui-ci,

(ii) jusqu'au 31 décembre 2025, si elles se trouvent à tout autre endroit.

(2) Il est permis, jusqu'au 31 décembre 2025, d'utiliser les pièces d'équipement ci-après qui sont en usage le 5 septembre 2008 et qui contiennent des BPC en une concentration égale ou supérieure à 50 mg/kg :

a) les ballasts de lampes;

b) les transformateurs sur poteaux ainsi que tout équipement électrique connexe sur poteaux.

Ballasts de
lampes et
transformateurs
sur poteaux

Current transformers and other equipment

(2.1) A person may, from January 1, 2015 until December 31, 2025, use any current transformers, potential transformers, circuit breakers, reclosers and bushings that are located at an electrical generation, transmission or distribution facility and contain PCBs in a concentration of 500 mg/kg or more if that equipment is in use on September 5, 2008.

(2.1) À compter du 1^{er} janvier 2015 jusqu'au 31 décembre 2025, il est permis d'utiliser les transformateurs d'intensité, transformateurs de potentiel, disjoncteurs, disjoncteurs à réenclenchement et traversées isolées se trouvant dans une installation de production, de transmission ou de distribution d'électricité qui sont en usage le 5 septembre 2008 et qui contiennent des BPC en une concentration égale ou supérieure à 500 mg/kg.

Transformateurs d'intensité et autre équipement électrique

Liquid — authorized concentration

(3) A person may use a liquid containing PCBs in a concentration of 2 mg/kg or more but less than 50 mg/kg in equipment until the day on which the liquid is removed from the equipment.

(3) Il est permis d'utiliser tout liquide qui contient des BPC en une concentration égale ou supérieure à 2 mg/kg, mais inférieure à 50 mg/kg dans une pièce d'équipement jusqu'à ce qu'il en soit extrait.

Liquides — concentration autorisée

SOR/2010-57, s. 19; SOR/2014-75, s. 3.

DORS/2010-57, art. 19; DORS/2014-75, art. 3.

Extension of end-of-use date

17. (1) Despite subsection 15(2), paragraph 16(1)(a) and subparagraph 16(1)(b)(i), a person may use the equipment and the liquids used for servicing that equipment, referred to in those provisions, until the date set out in an extension granted by the Minister under subsection (2) for that equipment and those liquids.

17. (1) Malgré le paragraphe 15(2), l'alinéa 16(1)a) et le sous-alinéa 16(1)b)(i), il est permis d'utiliser les pièces d'équipement et les liquides utilisés pour leur entretien visés à ces dispositions jusqu'à l'expiration de toute prolongation accordée par le ministre en vertu du paragraphe (2) pour ces pièces d'équipement et ces liquides.

Prolongation de la date de fin d'utilisation

Application

(2) The Minister shall, on receiving a written application containing the information set out in subsection (3), grant an extension up to the date applied for but no later than December 31, 2014, if either of the following conditions are met:

(2) Sur réception d'une demande écrite comportant les renseignements prévus au paragraphe (3), le ministre accorde une prolongation jusqu'à la date prévue dans la demande mais au plus tard jusqu'au 31 décembre 2014, si l'une ou l'autre des conditions suivantes est remplie :

Demande

(a) the equipment is being replaced with equipment that is engineered to order, and

a) la pièce d'équipement doit être remplacée par une pièce d'équipement conçue et fabriquée sur mesure et :

(i) it is not technically feasible to replace the equipment on or before December 31, 2009,

(i) il est techniquement impossible de le faire le 31 décembre 2009 ou avant cette date,

(ii) the applicant is taking all necessary measures to minimize or eliminate any harmful effect of the PCBs in

(ii) le demandeur prend les mesures nécessaires pour éliminer ou atténuer

the equipment on the environment and on human health,

(iii) a plan has been prepared, along with timelines, to end the use of the equipment by the date applied for,

(iv) a plan has been prepared for inspecting the equipment on a monthly basis for the period of the extension for damage that could lead to the release of PCBs, and

(v) the equipment bears the label required under section 29; or

(b) the equipment is located at a facility that is scheduled for permanent closure on or before December 31, 2014, and

(i) the applicant is taking all necessary measures to minimize or eliminate any harmful effect of the PCBs in the equipment on the environment and on human health,

(ii) a plan has been prepared, along with timelines, to end the use of the equipment by the date applied for,

(iii) a plan has been prepared for inspecting the equipment on a monthly basis, for the period of the extension, for damage that could lead to the release of PCBs, and

(iv) the equipment bears the label required under section 29.

tout effet nocif des BPC contenus dans la pièce sur l'environnement et la santé humaine,

(iii) un plan, incluant un échéancier, a été dressé afin que l'utilisation de la pièce cesse au plus tard à la date prévue dans la demande,

(iv) un plan a été dressé pour l'inspection de la pièce une fois par mois durant la prolongation afin que soit décelé tout dommage pouvant mener au rejet de BPC,

(v) la pièce porte l'étiquette exigée par l'article 29;

b) la pièce d'équipement se trouve dans une installation dont la fermeture permanente est prévue au plus tard pour le 31 décembre 2014 et :

(i) le demandeur prend les mesures nécessaires pour éliminer ou atténuer tout effet nocif des BPC contenus dans la pièce sur l'environnement et la santé humaine,

(ii) un plan, incluant un échéancier, a été dressé afin que l'utilisation de la pièce cesse au plus tard à la date prévue dans la demande,

(iii) un plan a été dressé pour l'inspection de la pièce une fois par mois durant la prolongation afin que soit décelé tout dommage pouvant mener au rejet de BPC;

(iv) la pièce porte l'étiquette exigée par l'article 29.

Information

(3) The application shall contain the following:

(a) the name, civic and mailing addresses, telephone number, fax number, if any, and e-mail address, if any, of the

(3) La demande comporte :

a) les nom, adresses municipale et postale et numéro de téléphone du demandeur et de toute personne autorisée à agir en son nom et, le cas échéant, leurs nu-

Renseignements

applicant and of any person authorized to act on the applicant's behalf;

(b) a technical description of the equipment which is the subject of the application, including

- (i) the type and function of the equipment,
- (ii) the quantity of liquid containing PCBs that is in the equipment and the quantity of liquid needed for servicing that equipment, expressed in litres,
- (iii) the concentration of PCBs in the liquid, expressed in milligrams of PCBs per kilogram of liquid,
- (iv) the quantity of PCBs in the liquid that is in the equipment, expressed in kilograms, and
- (v) the name-plate description, if any, and the manufacturer's serial number, if any;

(c) the unique identification number that is on the label required under section 29;

(d) the name, if any, and civic address of the facility where the equipment is located, or, if there is no civic address, the location using the owner's site identification system, and the function and technical description of the facility;

(e) information demonstrating that

- (i) it is not technically feasible to replace the equipment on or before December 31, 2009, or
- (ii) the facility where the equipment is located is scheduled for permanent closure on or before December 31, 2014;

(f) information demonstrating that the applicant is taking all necessary mea-

surements of the equipment, including the number of copier and electronic address;

b) les caractéristiques techniques de la pièce d'équipement qui fait l'objet de la demande, notamment :

- (i) son type et sa fonction,
- (ii) la quantité de liquide qui contient des BPC qui s'y trouve et la quantité de liquide nécessaire pour son entretien, exprimées en litres,
- (iii) la concentration de BPC dans le liquide, exprimée en milligrammes de BPC par kilogramme de liquide,
- (iv) la quantité de BPC dans le liquide qui s'y trouve, exprimée en kilogrammes,
- (v) s'il y a lieu, l'information figurant sur la plaque d'identification et le numéro de série de son fabricant;

c) le numéro d'identification unique figurant sur l'étiquette en application de l'article 29;

d) le nom, s'il y a lieu, et l'adresse municipale de l'installation où se trouve la pièce d'équipement ou, à défaut, l'endroit où elle se trouve d'après le système d'identification de site du propriétaire, et la fonction et les caractéristiques techniques de l'installation;

e) les renseignements qui établissent :

- (i) soit qu'il est techniquement impossible de remplacer la pièce d'équipement le 31 décembre 2009 ou avant cette date,
- (ii) soit que la fermeture permanente de l'installation dans laquelle se trouve la pièce d'équipement est pré-

asures to minimize or eliminate any harmful effect of the PCBs that are contained in the equipment on the environment and on human health;

(g) the plan, along with timelines, for ending the use of the equipment; and

(h) the plan for inspecting the equipment.

vue au plus tard pour le 31 décembre 2014;

f) les renseignements qui établissent que les mesures nécessaires ont été prises par le demandeur pour éliminer ou atténuer tout effet nocif des BPC contenus dans la pièce d'équipement sur l'environnement et la santé humaine;

g) le plan et l'échéancier qui seront mis en oeuvre afin que cesse l'utilisation de la pièce d'équipement;

h) le plan d'inspection de la pièce d'équipement.

Notice of change to information

(4) The applicant shall notify the Minister in writing of any change to the information provided under subsection (3) within 30 days after the day on which the change occurs.

(4) Le demandeur est tenu d'aviser le ministre par écrit de tout changement apporté aux renseignements fournis en application du paragraphe (3) dans les trente jours suivant la date du changement.

Avis de changement apporté aux renseignements

False or misleading information

(5) The Minister shall refuse to grant an extension if the Minister has reasonable grounds to believe that the applicant has provided false or misleading information in support of its application.

(5) Le ministre refuse d'accorder une prolongation s'il a des motifs raisonnables de croire que le demandeur a fourni des renseignements faux ou trompeurs au soutien de sa demande.

Renseignements faux ou trompeurs

Revocation

(6) The Minister shall revoke the extension if

(6) Il révoque la prolongation :

Révocation

(a) the requirements set out in subsection (2) are no longer met during the period of the extension; or

a) si, durant la prolongation, les conditions prévues au paragraphe (2), selon le cas, ne sont plus remplies;

(b) the Minister has reasonable grounds to believe that the applicant has provided false or misleading information to the Minister in support of its application.

b) s'il a des motifs raisonnables de croire que le demandeur lui a fourni des renseignements faux ou trompeurs au soutien de sa demande.

Reasons for revocation

(7) The Minister shall not revoke the extension unless the Minister provides the applicant with

(7) Il ne peut toutefois révoquer la prolongation que si, à la fois :

Motifs de révocation

(a) written reasons for the revocation; and

a) il a avisé le titulaire par écrit des motifs de la révocation;

(b) an opportunity to be heard, by written representation, in respect of the revocation.

SOR/2010-57, s. 6(F).

b) il lui a donné la possibilité de présenter des observations par écrit au sujet de celle-ci.

DORS/2010-57, art. 6(F).

PART 3

STORAGE

Application — concentration of 50 mg/kg or more

18. (1) Subject to subsection (3), this Part applies to all solids and liquids containing PCBs in a concentration of 50 mg/kg or more that are located at a particular site if the liquids or solids are present in a quantity greater than or equal to

- (a) 100 L, in the case of liquids; and
- (b) 100 kg, in the case of solids.

Application — quantity of 1 kg or more

(2) Subject to subsection (3), this Part also applies to all solids and liquids containing PCBs in a concentration of 50 mg/kg or more that are located at a particular site in a quantity of less than 100 L, in the case of liquids, and 100 kg, in the case of solids, if the total quantity of PCBs contained in the liquids or the solids or in the liquids and solids combined, determined in accordance with the following formulas, as applicable, is 1 kg or more:

- (a) in the case of liquids,

$$\Sigma \frac{(V \times D \times C)}{1\,000\,000}$$

where

V is the volume of each liquid containing PCBs in a given concentration, expressed in L,

D is the density of PCBs in each liquid as follows:

PARTIE 3

STOCKAGE

Application — concentration égale ou supérieure à 50 mg/kg

18. (1) Sous réserve du paragraphe (3), la présente partie s'applique à tout liquide et à tout solide qui contient des BPC en une concentration égale ou supérieure à 50 mg/kg et qui se trouve en la quantité ci-après dans un même emplacement :

- a) dans le cas d'un liquide, égale ou supérieure à 100 L;
- b) dans le cas d'un solide, égale ou supérieure à 100 kg.

Application — quantité de 1 kg ou plus

(2) Sous réserve du paragraphe (3), la présente partie s'applique également à tout liquide et à tout solide qui contient des BPC en une concentration égale ou supérieure à 50 mg/kg et qui se trouve dans un même emplacement en une quantité inférieure à 100 L, dans le cas d'un liquide, ou inférieure à 100 kg, dans le cas d'un solide, si le liquide, le solide ou la combinaison des deux renferment une quantité totale égale ou supérieure à 1 kg de BPC calculée conformément à la formule applicable suivante :

- a) dans le cas de tout liquide :

$$\Sigma \frac{(V \times D \times C)}{1\,000\,000}$$

où :

V représente le volume de chaque liquide contenant des BPC en une concentration donnée, exprimé en L,

D la densité des BPC dans chaque liquide :

(i) 0.9 kg/L, if the concentration of PCBs in the liquid is less than 10 000 mg/kg, and

(ii) 1.5 kg/L, if the concentration of PCBs in the liquid is 10 000 mg/kg or more, and

C is the concentration of PCBs in each liquid, expressed in mg/kg; and

(b) in the case of solids,

$$\Sigma \frac{(M \times C)}{1\,000\,000}$$

where

M is the weight of each solid containing PCBs in a given concentration, expressed in kg, and

C is the concentration of PCBs in each solid, expressed in mg/kg.

Non-application

(3) This Part does not apply in respect of the following products containing PCBs:

(a) solid or liquid products that are processed daily or used;

(b) pipelines that transport natural gas, petroleum or petroleum products, and any associated equipment that is in contact with the natural gas, petroleum or petroleum products, if they remain in place on September 5, 2008; and

(c) cables, if they remain in place on September 5, 2008.

SOR/2010-57, s. 19; SOR/2014-75, s. 4.

Requirement to store

19. (1) A person who owns, controls or possesses PCBs or products containing PCBs shall, within 30 days after the day on which those PCBs or products cease to be

(i) si la concentration des BPC est inférieure à 10 000 mg/kg, 0,9 kg/L,

(ii) si la concentration des BPC est supérieure ou égale à 10 000 mg/kg, 1,5 kg/L,

C la concentration des BPC dans chaque liquide, exprimée en mg/kg;

b) dans le cas de tout solide,

$$\Sigma \frac{(M \times C)}{1\,000\,000}$$

où :

M représente la masse de chaque solide contenant des BPC en une concentration donnée, exprimée en kg

C la concentration des BPC dans chaque solide, exprimée en mg/kg

Exclusion

(3) La présente partie ne s'applique pas aux produits ci-après qui contiennent des BPC :

a) les produits liquides ou solides qui sont transformés quotidiennement ou utilisés;

b) tout pipeline qui transporte du gaz naturel, du pétrole ou des produits pétroliers, ainsi que tout équipement connexe qui est en contact avec le gaz naturel, le pétrole ou les produits pétroliers, si le pipeline et l'équipement demeurent à l'endroit où ils se trouvaient le 5 septembre 2008;

c) les câbles, s'ils demeurent à l'endroit où ils se trouvaient le 5 septembre 2008.

DORS/2010-57, art. 19; DORS/2014-75, art. 4.

Obligation de stocker

19. (1) Le propriétaire de BPC ou de produits qui en contiennent ou la personne qui en a la possession ou le contrôle est tenu, dans les trente jours suivant la date où ceux-ci cessent d'être transformés quoti-

processed daily or used or after September 5, 2008, whichever is later, either

- (a) send them for destruction to an authorized facility that is authorized for that purpose; or
- (b) store them at a PCB storage site for the period during which they are not processed daily or used.

Remote from or no access to roadway

(2) Despite subsection (1), if the PCBs or products containing PCBs are remote from a roadway system or if there is no access to a roadway system, the person who owns, controls or possesses the PCBs or products may store them at a PCB storage site as soon as feasible but no later than one year after the day on which they are not processed daily or used or one year after September 5, 2008, whichever is later. That person shall use best management practices for them from the time that they cease to be processed daily or used until the time that they are stored at a PCB storage site.

SOR/2010-57, s. 7.

Prohibition against storage

20. (1) Effective September 5, 2009, no person shall store PCBs or products containing PCBs at the following plants or facilities or on the land on which those plants or facilities are located and within 100 m of them:

- (a) a drinking water treatment plant or a food or feed processing plant; or
- (b) a child care facility, preschool, primary school, secondary school, hospital, or senior citizens' care facility.

diennement ou utilisés ou suivant le 5 septembre 2008, selon la plus tardive de ces dates :

- a) soit de les expédier pour qu'ils soient détruits dans une installation agréée à cette fin;
- b) soit de les stocker dans un dépôt de BPC pendant qu'ils ne sont pas transformés quotidiennement ou utilisés.

(2) Si les BPC ou les produits qui en contiennent sont éloignés de tout système routier ou se trouvent à un endroit où il n'y a pas d'accès à un tel système, le propriétaire ou la personne peut les stocker dans un dépôt de BPC le plus tôt possible, sans toutefois dépasser un an à compter de la date où ils cessent d'être transformés quotidiennement ou utilisés ou du 5 septembre 2008, selon la plus tardive de ces dates. Ils sont tenus d'appliquer des pratiques exemplaires de gestion pour les BPC et les produits dès qu'ils cessent d'être transformés quotidiennement ou utilisés, et ce, jusqu'à leur stockage dans un dépôt de BPC.

DORS/2010-57, art. 7.

Endroit éloigné ou inaccessible

20. (1) À compter du 5 septembre 2009, il est interdit de stocker des BPC ou des produits qui en contiennent dans l'un des établissements ci-après ou sur le terrain d'un tel établissement, à 100 m ou moins de celui-ci :

- a) une usine de traitement d'eau potable ou de transformation des aliments destinés aux humains ou aux animaux;
- b) une garderie, une école — de niveau préscolaire, primaire ou secondaire —, un hôpital ou une résidence pour personnes âgées.

Interdiction de stocker

Light ballasts	<p>(2) Subsection (1) does not apply to light ballasts.</p> <p>SOR/2010-57, s. 8.</p>	<p>(2) Le paragraphe (1) ne s'applique pas aux ballasts de lampes.</p> <p>DORS/2010-57, art. 8.</p>	Ballasts de lampes
Maximum storage periods	<p>21. (1) Despite any other provision in these Regulations and subject to section 22, no person shall store PCBs or products containing PCBs, other than those referred to in section 23, beyond the following time limits:</p> <p>(a) one year, beginning on the day on which their use is no longer permitted under these Regulations or the day on which they are no longer processed daily or used, whichever is sooner, if the PCBs or products are stored at a facility that is not referred to in paragraph (1)(b) or (c);</p> <p>(b) one year, if the PCBs or products are stored at an authorized facility that is a transfer site; and</p> <p>(c) two years, if the PCBs or products are stored at an authorized facility that is authorized to destroy them.</p>	<p>21. (1) Malgré toute autre disposition du présent règlement mais sous réserve de l'article 22, il est interdit de stocker des BPC et des produits qui en contiennent, autres que ceux visés à l'article 23, au-delà de la période applicable suivante :</p> <p>a) un an à compter du jour où le présent règlement ne permet plus l'utilisation des BPC et des produits ou de celui, s'il est antérieur, où ils ont cessé d'être transformés quotidiennement ou utilisés, s'ils sont stockés à une installation qui n'est pas visée aux alinéas (1)b) ou c);</p> <p>b) un an, s'ils sont stockés dans une installation agréée qui est un centre de transfert;</p> <p>c) deux ans, s'ils sont stockés dans une installation agréée qui est autorisée à les détruire.</p>	Périodes maximales de stockage
Transfer sites	<p>(2) If the PCBs or products containing PCBs are sent from one transfer site to another, the period referred to in paragraph (1)(b) begins when they are received at the first transfer site.</p>	<p>(2) Si les BPC et les produits qui en contiennent sont expédiés d'un centre de transfert à un autre, la période prévue à l'alinéa (1)b) commence à courir le jour de leur réception au premier centre de transfert.</p>	Centres de transfert
Destruction	<p>(3) The owner or operator of the facility referred to in paragraph (1)(a) or (b) shall send the PCBs or products containing PCBs for destruction to an authorized facility that is authorized for that purpose within the time limit set out in those paragraphs.</p>	<p>(3) Le propriétaire ou l'exploitant de l'installation visée aux alinéas (1)a) ou b) est tenu d'expédier, dans le délai prévu à ces alinéas, les BPC ou les produits qui en contiennent pour qu'ils soient détruits dans une installation agréée à cette fin.</p>	Destruction
Exceptions to maximum storage periods	<p>22. (1) Section 21 does not apply to the storage of</p>	<p>22. (1) L'article 21 ne s'applique pas au stockage :</p> <p>a) des liquides visés au paragraphe 15(2) ou pour lesquels une pro-</p>	Périodes maximales de stockage — exceptions

(a) liquids referred to in subsection 15(2) or for which an extension has been granted under subsection 17; or

(b) for the duration of any environmental remediation work, solids and liquids containing PCBs in a concentration of 50 mg/kg or more resulting from that work and stored on site for that duration, if the requirements set out in subsections (2) and (3) are complied with.

Information to be provided

(2) The owner of the land where the solids and liquids referred to in paragraph (1)(b) are located shall submit to the Minister at least 30 days before the storage of the solids or liquids or within 30 days after September 5, 2008, whichever is later, the following information:

(a) the civic address of the restoration work site or if there is no civic address, the location using the Global Positioning System;

(b) the date of commencement of the restoration work;

(c) the anticipated date of completion of the restoration work; and

(d) the anticipated date of the end of storage of the solids or liquids.

Changes to information

(3) The person referred to in subsection (2) shall notify the Minister in writing of the changes to be made at least 30 days before making any changes to the information provided under that subsection.

SOR/2010-57, s. 9; SOR/2014-75, s. 5.

PCBs or products containing PCBs stored on September 5, 2008

23. A person who owns, controls or possesses PCBs or products containing PCBs, other than liquids for which an extension has been granted under section 17, that are stored on September 5, 2008 may store them

longation a été accordée en vertu de l'article 17;

b) durant des travaux de restauration de l'environnement, des solides et des liquides qui contiennent des BPC en une concentration égale ou supérieure à 50 mg/kg et qui sont issus de ces travaux, s'ils sont stockés sur place pendant la durée de ces mêmes travaux et si les exigences prévues aux paragraphes (2) et (3) sont respectées.

Renseignements à fournir

(2) Le propriétaire du terrain où se trouvent les solides ou les liquides visés à l'alinéa (1)b) fournit au ministre, au plus tard trente jours avant la date de leur stockage ou trente jours après le 5 septembre 2008, selon la plus tardive de ces dates, les renseignements suivants :

a) l'adresse municipale de l'endroit où sont effectués les travaux de restauration ou, à défaut, sa localisation d'après le système mondial de localisation;

b) la date de début des travaux de restauration;

c) la date prévue pour la fin des travaux de restauration;

d) la date prévue pour la cessation du stockage des solides ou des liquides.

Modification des renseignements

(3) Il avise également le ministre par écrit, au moins trente jours à l'avance, de toute modification apportée aux renseignements fournis.

DORS/2010-57, art. 9; DORS/2014-75, art. 5.

BPC et produits qui en contiennent stockés le 5 septembre 2008

23. Le propriétaire ou la personne qui a la possession ou le contrôle de BPC ou de produits qui en contiennent, autres que des liquides visés par une prolongation au titre de l'article 17, qui sont stockés en date du

(a) until December 31, 2009 if they are sent by that date for destruction to an authorized facility that is authorized for that purpose; or

(b) until December 31, 2011 if they are destroyed by that date, at the location where they are stored, in an authorized facility that is authorized for that purpose.

SOR/2010-57, s. 10; SOR/2014-75, s. 6(E).

PCB storage site

24. PCBs or products containing PCBs shall be stored at a site that is

(a) a building, room, shipping container or other enclosed structure; or

(b) an area that is enclosed by a woven mesh wire fence or any other fence or wall with similar security characteristics, and the fence or wall shall be at least 1.83 m high.

Storage requirements

25. The owner or operator of a PCB storage site shall

(a) store all PCBs or products containing PCBs that are in liquid form in

(i) sealed containers, other than drums, that are made of steel or other metals that provide sufficient durability and strength to prevent those PCBs or products from being affected by the weather or released, or

(ii) drums that are

(A) of a capacity not greater than 205 L,

(B) a closed-head double-bung drum made of steel having a gauge of 16 or heavier, and

5 septembre 2008 est autorisé à les stocker :

a) jusqu'au 31 décembre 2009, s'ils sont expédiés, au plus tard à cette date, pour être détruits dans une installation agréée à cette fin;

b) jusqu'au 31 décembre 2011, s'ils sont détruits, au plus tard à cette date, dans une installation agréée à cette fin se trouvant à l'emplacement de stockage.

DORS/2010-57, art. 10; DORS/2014-75, art. 6(A).

Dépôt de BPC

24. Les BPC et les produits qui en contiennent doivent être stockés dans un dépôt qui est :

a) soit un bâtiment, une pièce, un conteneur ou tout autre ouvrage fermé;

b) soit un endroit entouré d'une clôture grillagée ou d'un autre genre de clôture ou d'un mur présentant des caractéristiques similaires sur le plan de la sécurité, la clôture ou le mur ayant au moins 1,83 m de haut.

Exigences relatives au stockage

25. Le propriétaire ou l'exploitant d'un dépôt de BPC :

a) stocke les BPC et les produits en contenant qui sont des liquides dans :

(i) soit des contenants étanches, autres que des fûts, faits d'acier ou d'autres métaux offrant une durabilité et une solidité suffisantes pour que ces BPC et ces produits ne soient pas affectés par les conditions climatiques ni rejetés,

(ii) soit des fûts qui, à la fois :

(A) ont une capacité d'au plus 205 L,

(B) sont faits d'acier d'épaisseur minimale 16, ont un dessus non

- (C) painted or treated to prevent rusting;
- (b) store all PCBs or products containing PCBs that are in solid form in
- (i) containers, other than drums, that are made of steel or other materials that provide sufficient durability and strength to prevent those PCBs or products from being affected by the weather or released, or
- (ii) drums that are
- (A) of a capacity not greater than 205 L,
- (B) made of steel having a gauge of 18 or heavier,
- (C) equipped with a securely attached, removable steel lid and a gasket made of material that is resistant to the PCBs or the products containing PCBs that are stored in the drums, and
- (D) painted or treated to prevent rusting;
- (c) store equipment containing PCB liquids in
- (i) containers, other than drums, that are made of steel or other materials that provide sufficient durability and strength to prevent the equipment from being affected by the weather and to prevent any PCB liquid that leaks from the equipment from being released, or
- (ii) drums described in subparagraph (b)(ii);
- (d) store all equipment that is not in a container, other than drained equipment, if that equipment contains PCB liquid,
- amovible et sont munis de deux bondes,
- (C) sont enduits d'une peinture ou d'un revêtement antirouille;
- b) stocke les BPC et les produits en contenant qui sont des solides dans :
- (i) soit des contenants, autres que des fûts, faits d'acier ou d'autres matériaux offrant une durabilité et une solidité suffisantes pour que ces BPC et ces produits ne soient pas affectés par les conditions climatiques ni rejetés,
- (ii) soit des fûts qui, à la fois :
- (A) ont une capacité d'au plus 205 L,
- (B) sont faits d'acier d'épaisseur minimale 18,
- (C) sont dotés d'un couvercle d'acier amovible solidement fixé et d'un joint fait d'un matériau résistant aux BPC et aux produits en contenant qui y sont stockés,
- (D) sont enduits d'une peinture ou d'un revêtement antirouille;
- c) stocke les pièces d'équipement qui renferment des liquides contenant des BPC dans :
- (i) soit des contenants, autres que des fûts, faits d'acier ou d'autres matériaux offrant une durabilité et une solidité suffisantes pour que les pièces d'équipement ne soient pas affectées par les conditions climatiques et que les liquides, s'ils fuient des pièces, ne soient pas rejetés,
- (ii) soit des fûts visés au sous-alinéa b)(ii);

and all containers of PCB liquid, on a floor or surface that is made of steel, concrete or any other similar durable material and that is constructed with curbing or sides that are capable of containing

(i) if one piece of equipment or one container is being stored, 125% of the volume of the PCB liquid in the equipment or container, and

(ii) if more than one piece of equipment or more than one container is being stored, the greater of twice the volume of the PCB liquid in the largest piece of equipment or the largest container and 25% of the volume of all the PCB liquid stored on the floor or surface;

(e) if the material of the floor or surface or the curbing or sides referred to in paragraph (d) are capable of absorbing any PCB liquid or other product containing PCBs, seal the floor, surface, curbing or sides with an impervious, durable, PCB-resistant coating;

(f) ensure that all floor drains, sumps or other openings in the floor or surface referred to in paragraph (d) are

(i) closed and sealed to prevent the release of liquids, or

(ii) connected to a drainage system suitable for liquid dangerous goods that terminates at a location where any spilled liquids will be contained and recovered and where the spilled liquids will not create a fire hazard or a risk to public health or safety;

(g) place on skids or pallets all equipment containing PCBs and containers of PCBs or products containing PCBs that

d) stocke les pièces d'équipement — autres que celles contenant des BPC qui ont été vidangées — qui ne sont pas dans un contenant et qui renferment des liquides contenant des BPC, ainsi que tout contenant qui renferme de tels liquides, sur un plancher ou une surface fait d'acier, de béton ou d'un autre matériau durable semblable et entouré d'un rebord ou de côtés capables de retenir :

(i) si une seule pièce d'équipement ou un seul contenant est stocké, 125 % du volume des liquides contenant des BPC que renferme cette pièce d'équipement ou le contenant,

(ii) si plus d'une pièce d'équipement ou plus d'un contenant est stocké, le plus élevé des volumes suivants : le double du volume des liquides contenant des BPC que renferme la plus grosse pièce d'équipement ou le plus grand contenant ou 25 % du volume de l'ensemble des liquides contenant des BPC qui sont stockés sur le plancher ou la surface;

e) scelle, au moyen d'un revêtement étanche, durable et résistant aux BPC, le plancher, la surface, le rebord ou les côtés visés à l'alinéa d), lorsqu'ils peuvent absorber des liquides ou d'autres produits qui contiennent des BPC;

f) veille à ce que les drains de sol, puits et autres ouvertures dans le plancher ou la surface visés à l'alinéa d) soient, selon le cas :

(i) obturés et scellés pour empêcher le rejet de liquides,

(ii) reliés à un réseau de drainage convenant aux marchandises dangereuses liquides, qui se jette dans un

are not permanently secured to the floor or a surface;

(h) stack containers of PCBs and products containing PCBs, other than drums, only if the containers are designed for stacking, and stack containers of PCB liquid not more than two containers high;

(i) if drums containing PCBs or products containing PCBs are stacked, separate the drums from each other with pallets and, in the case of drums of PCB liquid, stack the drums not more than two drums high;

(j) store equipment containing PCBs, and containers of PCBs or products containing PCBs, in a manner that makes them accessible for inspection;

(k) store PCBs or products containing PCBs in a manner that prevents them from catching fire or being released;

(l) store PCBs or products containing PCBs together, and separate them from other stored materials;

(m) if reasonably practicable, equip any indoor PCB storage site having a mechanical exhaust system with heat or smoke sensory controls that stop the fan and close the intake and exhaust dampers in the event of a fire;

(n) if equipment or containers of PCB liquid are stored outdoors, cover all PCB equipment that is not in a container, other than drained equipment, if that equipment contains PCB liquid, and all containers of PCB liquid, with a weatherproof roof or barrier that protects the equipment and containers and prevents rain or snow from entering the

lieu où les liquides déversés seront confinés et récupérés et où ils ne constitueront pas un risque d'incendie ni un risque pour la santé et la sécurité publiques;

g) place sur des patins ou des palettes les pièces d'équipement contenant des BPC et les contenants renfermant des BPC ou des produits en contenant qui ne sont pas fixés de façon permanente à un plancher ou à une surface;

h) empile les contenants de BPC et de produits qui en contiennent, autres que les fûts, seulement s'ils sont conçus à cette fin et, dans le cas des contenants renfermant des liquides qui contiennent des BPC, ne les empile pas à plus de deux contenants de haut;

i) s'ils sont empilés, sépare les fûts de BPC et de produits qui en contiennent les uns des autres avec des palettes et, dans le cas des fûts renfermant des liquides qui contiennent des BPC, ne les empile pas à plus de deux fûts de haut;

j) stocke les pièces d'équipement qui contiennent des BPC et les contenants renfermant des BPC ou des produits qui en contiennent de manière à ce qu'ils soient accessibles à des fins d'inspection;

k) stocke les BPC et les produits qui en contiennent de façon à empêcher leur inflammation ou leur rejet;

l) stocke les BPC et les produits qui en contiennent ensemble, à l'écart des autres matériaux stockés;

m) dans la mesure du possible, munit tout dépôt de BPC intérieur ayant un dispositif mécanique de ventilation de commandes sensibles à la chaleur ou à la fu-

curbing and the sides of the floor and the surface under them; and

(o) ensure that all drained PCB equipment and all containers of any PCB solid or PCB equipment are structurally sound and weatherproof if stored outdoors.

mée qui, en cas d'incendie, arrêtent le ventilateur et ferment les registres d'admission et d'évacuation d'air;

n) s'ils sont stockés dehors, couvre les pièces d'équipement — autres que celles contenant des BPC qui ont été vidangées — qui ne sont pas dans un contenant et qui renferment des liquides contenant des BPC, ainsi que tout contenant qui renferme de tels liquides, d'une toiture ou d'un écran à l'épreuve des intempéries qui les protège et empêche la pluie et la neige de pénétrer à l'intérieur du rebord et des côtés du plancher et de la surface sur lesquels ils sont posés;

o) s'ils sont stockés dehors, veille à ce que les pièces d'équipement contenant des BPC qui ont été vidangées et tout contenant qui renferme des solides ou des pièces d'équipement contenant des BPC aient une structure en bon état et soient à l'épreuve des intempéries.

Access to PCB storage site

26. The owner or operator of a PCB storage site shall keep all points of access to the PCB storage site locked or guarded.

26. Le propriétaire ou l'exploitant d'un dépôt de BPC tient chaque point d'accès au dépôt verrouillé ou veille à ce qu'il soit gardé.

Accès au dépôt de BPC

Inspection and maintenance of a PCB storage site

27. The owner or operator of a PCB storage site shall

(a) inspect all floors, curbing, sides, drains, drainage systems, weatherproof roofs and barriers, fences and walls of the PCB storage site, any fire alarm system, fire extinguishers and fire suppression system and all equipment containing PCBs, containers used for the storage of PCBs or products containing PCBs and materials for clean-up at the PCB storage site

(i) each month,

27. Le propriétaire ou l'exploitant d'un dépôt de BPC :

a) en inspecte les planchers, les rebords, les côtés, les drains, les réseaux de drainage, les toitures et écrans à l'épreuve des intempéries, les clôtures, les murs, le système d'alarme-incendie, les extincteurs et le réseau d'extinction automatique, ainsi que les pièces d'équipement qui contiennent des BPC, les contenants servant au stockage des BPC ou des produits qui en contiennent et les agents de nettoyage qui s'y trouvent :

(i) tous les mois,

Inspection et entretien des dépôts de BPC

(ii) at intervals of more than one month, if the Minister, on the written request of the owner or operator, determines that it is not reasonably practicable to inspect the site each month, due to its remote location, or

(iii) at intervals of less than one month, if more frequent inspections are necessary for the safe operation of the site; and

(b) keep in good condition and, if damaged, immediately repair or replace the floors, curbing, sides, drains, drainage systems, weatherproof roofs or barriers, fences, walls, fire alarm system, fire extinguishers, fire suppression system, equipment containing PCBs and containers and immediately clean up any contaminated area.

Fire protection
and emergency
procedures

28. (1) The owner or operator of a PCB storage site shall

(a) develop and implement at the PCB storage site a fire protection and emergency procedures plan and shall

(i) update and test the plan once per year,

(ii) keep a written copy of the latest plan at the PCB storage site and another at their principal place of business, and

(iii) make the latest plan readily available to persons who implement the plan and to the local fire department or to the local officer appointed by the provincial Fire Marshall if there is no local fire department or to any other local authority responsible for fire protection;

(b) ensure that all employees who are authorized to enter the PCB storage site

(ii) à des intervalles de plus d'un mois, si le ministre, à la demande écrite du propriétaire ou de l'exploitant, détermine qu'il est en pratique impossible d'inspecter le dépôt tous les mois en raison de son isolement,

(iii) à des intervalles de moins d'un mois, si l'exploitation du dépôt en toute sécurité exige des inspections plus fréquentes;

b) les garde en bon état et, en cas de dommage, les répare ou les remplace immédiatement et nettoie sur-le-champ les aires contaminées.

28. (1) Le propriétaire ou l'exploitant d'un dépôt de BPC :

a) élabore et met en oeuvre un plan d'intervention d'urgence et de lutte contre les incendies et :

(i) le met à jour et le vérifie annuellement,

(ii) en conserve une copie écrite à jour au dépôt et à son établissement principal,

(iii) en rend une copie à jour facilement accessible à toute personne qui participe à sa mise en oeuvre et au service d'incendie local ou, à défaut, au fonctionnaire local nommé par le commissaire provincial aux incendies ou à toute autre autorité locale chargée de la protection contre les incendies;

Protection
contre les
incendies et
mesures
d'urgence

are familiar with the contents of the latest plan;

(c) equip the indoor PCB storage site with a fully operative fire alarm system that is maintained, inspected and tested in accordance with articles 6.3.1.1 and 6.3.1.2 of the National Fire Code and with

(i) portable fire extinguishers that are selected and installed in accordance with article 2.1.5.1 of the National Fire Code and maintained, inspected and tested in accordance with article 6.2.1.1 of that Code, or

(ii) an automatic fire suppression system that meets the requirements of article 3.2.7.9 of the National Fire Code, if required;

(d) keep a copy of the records referred to in sections 43 and 44 at the PCB storage site and make a copy readily available to the local fire department and, if there is no local fire department, to the local officer appointed by the provincial Fire Marshall or to any other local authority responsible for fire protection;

(e) ensure that all employees who are authorized to enter the PCB storage site are made aware of the hazards of PCBs and are familiar with the use of protective equipment and clothing and the clean-up procedures referred to in the *Guidelines for the Management of Wastes Containing Polychlorinated Biphenyls (PCBs)*, CCME-TS/WM-TRE008, September 1989, as amended from time to time, issued by the Canadian Council of Ministers of the Environment; and

b) veille à ce que tous les employés autorisés à entrer dans le dépôt connaissent bien le contenu du plan à jour;

c) s'agissant d'un dépôt intérieur, le munit d'un système d'alarme-incendie en état de fonctionnement qui est entretenu, inspecté et mis à l'essai conformément aux exigences des articles 6.3.1.1 et 6.3.1.2 du Code national de prévention des incendies, ainsi que :

(i) soit d'extincteurs portatifs qui sont choisis et installés conformément à l'article 2.1.5.1 de ce code et qui sont entretenus, inspectés et mis à l'essai conformément aux exigences de l'article 6.2.1.1 de ce code,

(ii) soit d'un réseau d'extinction automatique conforme aux exigences de l'article 3.2.7.9 du même code, si celles-ci s'appliquent;

d) conserve au dépôt une copie des registres visés aux articles 43 et 44 et en rend une facilement accessible au service d'incendie local ou, à défaut, au fonctionnaire local nommé par le commissaire provincial aux incendies ou à toute autre autorité locale chargée de la protection contre les incendies;

e) veille à ce que tous les employés autorisés à entrer dans le dépôt soient informés des dangers que présentent les BPC et connaissent bien l'utilisation du matériel et des vêtements de protection et les méthodes de nettoyage mentionnées dans le *Guide pour la gestion des déchets contenant des biphényles polychlorés (BPC)* CCME-TS/WM-TRE008, septembre 1989, avec ses modifications successives, publié par le Conseil canadien des ministres de l'environnement;

(f) store absorbent materials for clean-up near the PCB storage site.

f) garde les matériaux absorbants servant au nettoyage près du dépôt.

Shipping containers

(2) Despite paragraph (1)(c), if the indoor PCB storage site is a shipping container, the owner or operator of the site does not have to equip that site with a fire alarm system.

(2) Malgré l'alinéa (1)c), le propriétaire ou l'exploitant d'un dépôt de BPC intérieur qui est un conteneur n'est pas tenu de le munir d'un système d'alarme-incendie.

Conteneur

DORS/2010-57, art. 11(F); DORS/2011-301, art. 4(F).

SOR/2010-57, s. 11(F); SOR/2011-301, s. 4(F).

PART 4

PARTIE 4

LABELLING, REPORTS AND RECORDS

ÉTIQUETAGE, RAPPORTS ET REGISTRES

[SOR/2011-301, s. 5(F)]

[DORS/2011-301, art. 5(F)]

LABELLING

ÉTIQUETAGE

Equipment and liquids used for their servicing

29. (1) The owner of equipment referred to in section 16, other than equipment for which an extension has been applied for under section 17, or of a liquid used in its servicing referred to in subsection 15(2) shall affix a label in a readily visible location on the equipment or on the container of the liquid, no later than 30 days after the day on which it ceases to be used.

29. (1) Le propriétaire d'une pièce d'équipement visée à l'article 16, autre qu'une pièce d'équipement qui fait l'objet d'une demande de prolongation en vertu de l'article 17, ou de tout liquide utilisé pour l'entretien visé au paragraphe 15(2) est tenu d'apposer une étiquette, à un endroit bien en vue sur la pièce d'équipement ou le contenant du liquide, au plus tard trente jours après que la pièce ou le contenant cesse d'être utilisé.

Pièces d'équipement et liquides pour leur entretien

Equipment for which extension applied for

(2) The owner of equipment for which an extension has been applied under section 17 shall affix a label in a readily visible location on the equipment.

(2) Le propriétaire d'une pièce d'équipement qui fait l'objet d'une demande de prolongation en vertu de l'article 17 est tenu d'y apposer une étiquette à un endroit bien en vue.

Équipement faisant l'objet d'une demande de prolongation

Exceptions

(3) Subsection (1) does not apply to
(a) equipment or containers of liquids that bear a label on September 5, 2008 that indicates the presence of PCBs; and
(b) equipment that is too small, including light ballasts, to bear the label referred to in subsection (4).

(3) Le paragraphe (1) ne s'applique pas :
a) aux pièces d'équipement et aux contenants de liquide qui portent, le 5 septembre 2008, une étiquette qui indique la présence de BPC;
b) aux pièces d'équipement qui sont trop petites, y compris les ballasts de

Exceptions

Containers for small equipment	(3.1) The owner of the equipment referred to in paragraph (3)(b) that is stored shall affix the label referred to in subsection (4) in a readily visible location on the container in which the equipment is stored.	lampes, pour que l'étiquette visée au paragraphe (4) y soit apposée.	Contenants de pièces d'équipement trop petites
Description	(4) The label must (a) state "ATTENTION — contains 50 mg/kg or more of PCBs / contient 50 mg/kg ou plus de BPC" in black lettering on a white background, in a font size of no less than 36 points; (b) measure at least 150 mm by 150 mm or at least 76 mm by 76 mm in the case of capacitors; and (c) in the case of equipment for which an extension is applied for under section 17, state a unique identification number.	(4) L'étiquette doit : a) porter la mention « ATTENTION — contains 50 mg/kg or more of PCBs / contient 50 mg/kg ou plus de BPC », inscrite en caractères d'au moins 36 points, en noir sur fond blanc; b) être d'une dimension minimale de 150 mm sur 150 mm ou, dans le cas d'un condensateur, 76 mm sur 76 mm; c) dans le cas d'une pièce d'équipement qui fait l'objet d'une demande de prolongation en vertu de l'article 17, porter un numéro d'identification unique.	Description
Cables and pipelines	30. (1) The owner of a cable, a pipeline or equipment associated with a pipeline, referred to in paragraphs 14(1)(a) and (b), containing PCBs in a concentration of 50 mg/kg or more that is in a room, a tunnel or a facility shall either (a) affix the label in the form set out in subsection 29(4) in a readily visible location on a part of the cable, pipeline or associated equipment that is accessible; or (b) place a notice in a readily visible location at the entrance of the room, tunnel or facility that states the information set out in paragraph 29(4)(a) and measures at least 150 mm by 150 mm.	DORS/2010-57, art. 12 et 19. 30. (1) Le propriétaire de câbles, de pipelines ou d'équipement connexe visés aux alinéas 14(1)(a) et (b) qui contiennent des BPC en une concentration égale ou supérieure à 50 mg/kg et se trouvent dans une pièce, un tunnel ou une installation est tenu : a) soit d'apposer une étiquette conforme au paragraphe 29(4) à un endroit bien en vue sur toute partie accessible du câble, pipeline ou équipement connexe; b) soit de placer à l'entrée de la pièce, du tunnel ou de l'installation à un endroit bien en vue une affiche d'une dimension minimale de 150 mm sur 150 mm portant la mention prévue à l'alinéa 29(4)a).	Câbles et pipelines

If dismantled

(2) If a part of the cable, pipeline or associated equipment is dismantled, the owner of the cable, pipeline or associated equipment shall affix on each dismantled part the label in the form set out in subsection 29(4), no later than 30 days after the day on which it is dismantled.

(2) En cas de désassemblage d'une partie du câble, du pipeline ou de l'équipement connexe, le propriétaire de ceux-ci est tenu, dans les trente jours suivant le désassemblage, d'apposer une étiquette conforme au paragraphe 29(4) sur chaque partie désassemblée du câble, du pipeline ou de l'équipement connexe.

Désassemblage

A facility other than transfer site or destruction facility

31. (1) The owner or operator of a PCB storage site, other than the PCB storage site of an authorized facility that is a transfer site or that is authorized to destroy PCBs, shall affix a label in a readily visible location on any product containing PCBs in a concentration of 50 mg/kg or more and that are stored at the PCB storage site, which

31. (1) Le propriétaire ou l'exploitant d'un dépôt de BPC d'une installation autre qu'une installation agréée qui est un centre de transfert ou qui est autorisée à détruire des BPC est tenu d'apposer une étiquette à un endroit bien en vue sur tout produit en contenant qui y sont stockés et qui contiennent des BPC en une concentration égale ou supérieure à 50 mg/kg; l'étiquette

Installation autre qu'un centre de transfert ou de destruction

(a) is in the form referred to in subsection 29(4); and

a) est conforme au paragraphe 29(4);

(b) states "Date of Commencement of Storage / Date de début de stockage" and the date on which the storage begins.

b) porte la mention « Date de début de stockage / Date of Commencement of Storage » et la date de début de stockage.

Transfer site or destruction facility

(2) The owner or operator of the PCB storage site of an authorized facility that is a transfer site or that is authorized to destroy PCBs shall affix a label in the form set out in subsection 29(4) in a readily visible location on any container that is a fixed tank and that is used at the facility for the storage of PCBs or products containing PCBs in a concentration of 50 mg/kg or more.

(2) Le propriétaire ou l'exploitant d'un dépôt de BPC d'une installation agréée qui est un centre de transfert ou qui est autorisée à détruire des BPC est tenu d'apposer une étiquette conforme au paragraphe 29(4) à un endroit bien en vue sur tout contenant qui est un réservoir fixe utilisé pour stocker des BPC à l'installation ou des produits qui en contiennent en une concentration égale ou supérieure à 50 mg/kg.

Centre de transfert ou de destruction

Notice

(3) The owner or operator of a PCB storage site shall place a notice in a readily visible location at the entrance of the site that states the information set out in paragraph 29(4)(a) and that measures at least 150 mm by 150 mm.

(3) Le propriétaire ou l'exploitant d'un dépôt de BPC place à l'entrée du dépôt à un endroit bien en vue une affiche d'une dimension minimale de 150 mm sur 150 mm portant la mention prévue à l'alinéa 29(4)a).

Affiche

Non-application

(4) Subsections (1) and (2) do not apply in respect of a product or container stored on September 5, 2008, if the product or the container

(a) bore a label on September 5, 2008 that indicated the presence of PCBs and that stated “Date of Commencement of Storage” and the date on which the storage began; and

(b) bears a label that states “Date of Commencement of Storage / Date de début de stockage” and the date on which the storage began.

SOR/2010-57, s. 13.

Retention of labels

32. The person who is required to affix a label on a product or container in accordance with sections 29 to 31 shall ensure that it bears that label for the duration that the person possesses the product or container.

REPORTS

End of use of equipment and liquids — 2009

33. (1) The owner of the equipment referred to in paragraph 16(1)(a) or subparagraph 16(1)(b)(i) — other than the equipment for which an extension is granted by the Minister in accordance with section 17 and the equipment referred to in subsection 16(2) or (2.1) — or of the liquids referred to in subsection 15(2) shall prepare a report that is current to December 31 of each calendar year in which the person owns the equipment or the liquids and that contains the following information:

(a) the name, civic and mailing addresses, telephone number, fax number, if any, and e-mail address, if any, of the owner and any person authorized to act on the owner’s behalf;

(b) for each piece of equipment, the civic addresses of the facilities where the

Non application

(4) Les paragraphes (1) et (2) ne s’appliquent pas au produit ou au contenant stocké en date du 5 septembre 2008, s’il respecte les conditions suivantes :

a) en date du 5 septembre 2008, il portait une étiquette indiquant la présence de BPC, la mention « Date de début de stockage » et la date de début de stockage;

b) il porte une étiquette portant la mention « Date de début de stockage / Date of Commencement of Storage » et la date de début de stockage.

DORS/2010-57, art. 13.

Conservation des étiquettes

32. La personne qui a l’obligation d’aposer une étiquette sur un produit ou un contenant en application des articles 29 à 31 veille à ce que le produit ou le contenant la porte en tout temps pendant qu’il est en sa possession.

RAPPORTS

Date de fin d’utilisation des pièces d’équipement et des liquides — 2009

33. (1) Le propriétaire des pièces d’équipement visées à l’alinéa 16(1)a) ou au sous-alinéa 16(1)b)(i) — autres que celles visées aux paragraphes 16(2) ou (2.1) ou pour lesquelles une prolongation a été accordée par le ministre en vertu de l’article 17 — ou des liquides visés au paragraphe 15(2) est tenu de préparer un rapport, au 31 décembre de chaque année civile durant laquelle il en est propriétaire, comportant les renseignements suivants :

a) ses nom, adresses municipale et postale, numéro de téléphone et, le cas échéant, numéro de télécopieur et adresse électronique, ainsi que ceux de toute personne autorisée à agir en son nom;

b) pour chaque pièce d’équipement, l’adresse municipale des installations où

equipment and liquids are located or, if there is no civic address, their location using the owner's site identification system;

(c) for each piece of equipment, the quantity of liquids containing PCBs in the equipment and of liquids, expressed in litres, the quantity of solids containing PCBs in the equipment, expressed in kilograms, and the concentration of PCBs in the liquids and solids, expressed in mg/kg,

- (i) that are in use on December 31,
- (ii) that are stored on December 31 at the person's PCB storage site,
- (iii) that are sent, in that calendar year, to an authorized facility that is a transfer site,
- (iv) that are sent, in that calendar year, to an authorized facility that is authorized to destroy them, or
- (v) that are destroyed in that calendar year; and

(d) a certification that the information is accurate and complete and that is dated and signed by the owner or by a person authorized to act on the owner's behalf.

(2) The owner of the equipment referred to in paragraph 16(1)(a) or subparagraph 16(1)(b)(i) — other than the equipment referred to in subsection 16(2) or (2.1) — or of the liquids referred to in subsection 15(2) for which an extension is granted by the Minister in accordance with section 17 shall prepare a report that is current to December 31 of each calendar year in which the person owns the equipment or the liquids and that contains the following information for each piece of equipment or container of liquid:

se trouve la pièce d'équipement et les liquides ou, à défaut, l'endroit où ils se trouvent d'après le système d'identification de site du propriétaire;

c) pour chaque pièce d'équipement, la quantité, exprimée en litres, de liquides qui contiennent des BPC dans la pièce d'équipement et de liquides, la quantité de solides qui contiennent des BPC dans les pièces d'équipement, exprimée en kilogrammes, et la concentration de BPC dans les liquides ou les solides, exprimée en mg/kg :

- (i) en usage le 31 décembre,
- (ii) stockés à son dépôt le 31 décembre,
- (iii) expédiés, au cours de l'année civile, à une installation agréée qui est un centre de transfert,
- (iv) expédiés, au cours de l'année civile, à une installation agréée qui est autorisée à les détruire,
- (v) détruits au cours de l'année civile;

d) une attestation, datée et signée par lui ou par toute personne autorisée à agir en son nom, portant que les renseignements sont complets et exacts.

(2) Le propriétaire des pièces d'équipement visées à l'alinéa 16(1)a) ou au sous-alinéa 16(1)b)(i) — autres que celles visées aux paragraphes 16(2) ou (2.1) — ou des liquides visés au paragraphe 15(2) pour lesquels une prolongation a été accordée par le ministre en vertu de l'article 17 est tenu de préparer un rapport, au 31 décembre de chaque année civile durant laquelle il en est propriétaire, comportant les renseignements ci-après pour chaque pièce d'équipement et contenant de liquides :

Equipment and liquids with extension

Pièces d'équipement et liquides pour lesquels une prolongation a été accordée

(a) the information required under paragraphs (1)(a) and (d);

(b) the unique identification number that is on the label referred to in paragraph 29(4)(c);

(c) the civic address, function and technical description of the facility where the equipment or container of liquid is located or, if there is no civic address, its location using the owner's site identification system;

(d) the progress on the plan's implementation and the timelines for ending the use of the equipment;

(e) the measures taken to minimize or eliminate any harmful effect of the PCBs in the equipment on the environment and on human health; and

(f) the findings of the inspections of the equipment.

(3) The owner of the equipment referred to in subparagraph 16(1)(b)(ii) and subsection 16(2) shall prepare a report that is current to December 31 of each calendar year in which the person owns the equipment and that contains the following information:

(a) the information required under paragraphs (1)(a) and (d);

(a.1) the civic addresses of the facilities where the equipment and liquids are located or, if there is no civic address, their location using the owner's site identification system; and

(b) the quantity of liquids containing PCBs in the equipment, expressed in litres, the quantity of solids containing

a) les renseignements prévus aux alinéas (1)a) et d);

b) le numéro d'identification unique figurant sur l'étiquette conformément à l'alinéa 29(4)c);

c) l'adresse municipale, la fonction et les caractéristiques techniques de l'installation où se trouvent la pièce d'équipement ou le contenant des liquides ou, à défaut, l'endroit où ils se trouvent d'après le système d'identification de site du propriétaire;

d) le progrès accompli dans la mise en oeuvre du plan et de l'échéancier dressé en vue de la cessation de l'utilisation de la pièce d'équipement;

e) les mesures prises pour éliminer ou atténuer tout effet nocif des BPC contenus dans la pièce d'équipement sur l'environnement et la santé humaine;

f) les résultats des inspections de la pièce d'équipement.

(3) Le propriétaire des pièces d'équipement visées au sous-alinéa 16(1)b)(ii) ou au paragraphe 16(2) est tenu de préparer un rapport, au 31 décembre de chaque année civile durant laquelle il en est propriétaire, comportant les renseignements suivants :

a) les renseignements prévus aux alinéas (1)a) et d);

a.1) l'adresse municipale des installations où se trouvent les pièces d'équipement et les liquides ou, à défaut, l'endroit où ils se trouvent d'après le système d'identification de site du propriétaire;

b) la quantité de liquides qui contiennent des BPC dans les pièces d'équipement, exprimée en litres, la

PCBs in the equipment, expressed in kilograms, and the concentration of PCBs in the liquids and the solids, expressed in mg/kg,

- (i) that are stored on December 31 at the person's PCB storage site,
- (ii) that are sent, in that calendar year, to an authorized facility that is a transfer site,
- (iii) that are sent, in that calendar year, to an authorized facility that is authorized to destroy them, or
- (iv) that are destroyed in that calendar year.

(4) The owner of the equipment referred to in subsection 16(2.1) shall prepare a report that is current to December 31 of each calendar year in which the person owns the equipment and that contains the following information:

(a) the information required under paragraphs (1)(a), (b) and (d); and

(b) for each piece of equipment, the quantity of liquids containing PCBs in the equipment, expressed in litres, the quantity of solids containing PCBs in the equipment, expressed in kilograms, and the concentration of PCBs in the liquids and the solids, expressed in mg/kg,

- (i) that are in use on December 31,
- (ii) that are stored on December 31 at the person's PCB storage site,
- (iii) that are sent, in that calendar year, to an authorized facility that is a transfer site,

quantité de solides qui contiennent des BPC dans les pièces d'équipement, exprimée en kilogrammes, et la concentration de BPC dans les liquides ou les solides, exprimée en mg/kg :

- (i) stockés à son dépôt de BPC le 31 décembre,
- (ii) expédiés, au cours de l'année civile, à une installation agréée qui est un centre de transfert,
- (iii) expédiés, au cours de l'année civile, à une installation agréée qui est autorisée à les détruire,
- (iv) détruits au cours de l'année civile.

(4) Le propriétaire des pièces d'équipement visées au paragraphe 16(2.1) est tenu de préparer un rapport, au 31 décembre de chaque année civile durant laquelle il en est propriétaire, comportant les renseignements suivants :

a) les renseignements prévus aux alinéas (1)a), b) et d);

b) pour chaque pièce d'équipement, la quantité de liquides qui contiennent des BPC dans la pièce d'équipement, exprimée en litres, la quantité de solides qui contiennent des BPC dans les pièces d'équipement, exprimée en kilogrammes, et la concentration de BPC dans les liquides ou les solides, exprimée en mg/kg :

- (i) en usage le 31 décembre,
- (ii) stockés à son dépôt de BPC le 31 décembre,
- (iii) expédiés, au cours de l'année civile, à une installation agréée qui est un centre de transfert,

End of use of
equipment —
2025

Date de fin
d'utilisation des
pièces
d'équipement —
2025

(iv) that are sent, in that calendar year, to an authorized facility that is authorized to destroy them, or

(v) that are destroyed in that calendar year.

SOR/2010-57, s. 14; SOR/2014-75, s. 7.

Research

34. The person who offers for sale, sells, processes or uses PCBs or products containing PCBs for the purpose of research in accordance with section 8 shall prepare a report that is current to December 31 in each calendar year in which the person offers for sale, sells, processes or uses those PCBs or products and that contains the following information:

(a) the name, civic and mailing addresses, telephone number, fax number, if any, and e-mail address, if any, of the person and of any person authorized to act on that person's behalf;

(b) an indication of whether the person offers for sale, sells, processes or uses the PCBs or products;

(c) the quantity of the PCBs or of the products containing PCBs that are offered for sale, sold, processed or used in that calendar year; and

(d) a certification that the information is accurate and complete and that is dated and signed by the person or by a person authorized to act on their behalf.

Colouring pigment

35. The person who manufactures, exports or imports colouring pigment in accordance with section 11 shall prepare a report that is current to December 31 in each calendar year in which the person manufactures, imports or exports the colouring pigment and that contains the following information:

(iv) expédiés, au cours de l'année civile, à une installation agréée qui est autorisée à les détruire,

(v) détruits au cours de l'année civile.

DORS/2010-57, art. 14; DORS/2014-75, art. 7.

Recherches

34. La personne qui met en vente, vend, transforme ou utilise des BPC ou des produits qui en contiennent en vue d'effectuer des recherches conformément à l'article 8 est tenue de préparer un rapport, au 31 décembre de chaque année civile durant laquelle elle les a mis en vente, vendus, utilisés ou transformés, comportant les renseignements suivants :

a) ses nom, adresses municipale et postale, numéro de téléphone et, le cas échéant, numéro de télécopieur et adresse électronique, ainsi que ceux de toute personne autorisée à agir en son nom;

b) une mention indiquant si elle les a mis en vente, vendus, transformés ou utilisés;

c) la quantité de BPC ou de produits qui ont été mis en vente, vendus, transformés ou utilisés durant l'année civile;

d) une attestation, datée et signée par elle ou par toute personne autorisée à agir en son nom, portant que les renseignements sont complets et exacts.

Pigments pour la coloration

35. La personne qui fabrique, exporte ou importe, conformément à l'article 11, des pigments pour la coloration est tenue de préparer un rapport, au 31 décembre de chaque année civile durant laquelle elle les fabrique, exporte ou importe, comportant les renseignements suivants :

a) ses nom, adresses municipale et postale, numéro de téléphone et, le cas

(a) the name, civic and mailing addresses, telephone number, fax number, if any, and e-mail address, if any, of the person and of any person authorized to act on that person's behalf;

(b) an indication of whether the person manufactures, exports or imports colouring pigment;

(c) the quantity of colouring pigment, expressed in kilograms, the maximum concentration of PCBs in the colouring pigment, expressed in mg/kg, and the average annual concentration of PCBs in the colouring pigment, expressed in mg/kg, that is manufactured, imported or exported in that calendar year;

(d) in the case of importing, the name, telephone number and civic and mailing addresses of the person from whom the colouring pigment is imported and, in the case of exporting, the name, telephone number and civic and mailing addresses of the person to whom the colouring pigment is exported; and

(e) a certification that the information is accurate and complete and that is dated and signed by the person or by a person authorized to act on their behalf.

Solid products
containing PCBs

36. The person who manufactures solid products containing PCBs in accordance with section 13 shall prepare a report that is current to December 31 in each calendar year in which the person manufactures the products and that contains the following information:

(a) the name, civic and mailing addresses, telephone number, fax number, if any, and e-mail address, if any, of the person and of any person authorized to act on that person's behalf;

échéant, numéro de télécopieur et adresse électronique, ainsi que ceux de toute personne autorisée à agir en son nom;

b) une mention indiquant si elle les a fabriqués, exportés ou importés;

c) la quantité, exprimée en kilogrammes, de pigments qui ont été fabriqués, exportés ou importés durant l'année civile ainsi que la concentration moyenne annuelle et la concentration maximale en BPC de ces pigments, exprimée en mg/kg;

d) les nom, adresses municipale et postal et numéro de téléphone de la personne de qui proviennent les pigments, dans le cas où ils sont importés, ou à qui ils sont expédiés, dans le cas où ils sont exportés;

e) une attestation, datée et signée par elle ou par toute personne autorisée à agir en son nom, portant que les renseignements sont complets et exacts.

36. La personne qui fabrique, conformément à l'article 13, des produits solides qui contiennent des BPC est tenue de préparer un rapport, au 31 décembre de chaque année civile durant laquelle elle les fabrique, comportant les renseignements suivants :

a) ses nom, adresses municipale et postale, numéro de téléphone et, le cas échéant, numéro de télécopieur et adresse électronique, ainsi que ceux de toute personne autorisée à agir en son nom;

Produits solides
qui contiennent
des BPC

(b) the quantity of solid products manufactured in that calendar year, expressed in kilograms, and the maximum concentration and average concentration of PCBs in the solid products, expressed in mg/kg, for that calendar year;

(c) the name, telephone number and civic and mailing addresses of the person to whom the manufacturer sells the products; and

(d) a certification that the information is accurate and complete and that is dated and signed by the person or by a person authorized to act on their behalf.

37. The person who owns and stores PCBs or products containing PCBs in a concentration of 50 mg/kg or more, other than the equipment and liquids referred to in section 33, and the owner of a facility who stores PCBs or products containing PCBs in a concentration of 50 mg/kg or more, other than the person referred to in section 38, shall each prepare a report that is current to December 31 in each calendar year in which the person stores the PCBs or products at their PCB storage site and that contains the following information:

(a) the name, civic and mailing addresses, telephone number, fax number, if any, and e-mail address, if any, of the owner and of any person authorized to act on the owner's behalf;

(b) the civic addresses of the PCB storage sites where the PCBs or products are located, or if there is no civic address, their location using the owner's site identification system;

(c) the quantity of liquids containing PCBs in the products, expressed in litres, and the quantity of solids containing

b) la quantité, exprimée en kilogrammes, de produits qui ont été fabriqués durant l'année civile ainsi que la concentration moyenne et la concentration maximale en BPC de ces produits, exprimée en mg/kg, pour cette année civile;

c) les nom, adresse municipale et postale et numéro de téléphone de la personne à qui elle a vendu les produits;

d) une attestation, datée et signée par elle ou par toute personne autorisée à agir en son nom, portant que les renseignements sont complets et exacts.

37. Le propriétaire de BPC ou de produits qui en contiennent en une concentration égale ou supérieure à 50 mg/kg, autres que les pièces d'équipement ou les liquides visés à l'article 33, et le propriétaire d'une installation, autre que celui visé à l'article 38, qui stockent à leur dépôt de BPC des BPC ou des produits qui en contiennent en cette concentration sont chacun tenus de préparer un rapport, au 31 décembre de chaque année civile durant laquelle ils les stockent ainsi, comportant les renseignements suivants :

a) ses nom, adresses municipale et postale, numéro de téléphone et, le cas échéant, numéro de télécopieur et adresse électronique, ainsi que ceux de toute personne autorisée à agir en son nom;

b) l'adresse municipale des dépôts où sont stockés les BPC et les produits ou, à défaut, l'endroit où ils se trouvent d'après le système d'identification de site du propriétaire;

c) la quantité de liquides qui contiennent des BPC dans les produits,

Stored PCBs or products — PCB concentration of 50 mg/kg or more

BPC ou produits stockés — concentration de BPC de 50 mg/kg ou plus

PCBs in the products, expressed in kilograms, and the concentration of PCBs in the liquids and the solids, expressed in mg/kg

- (i) that are stored on December 31 at the person's PCB storage site,
- (ii) that are sent, in that calendar year, to an authorized facility that is a transfer site,
- (iii) that are sent, in that calendar year, to an authorized facility that is authorized to destroy them, or
- (iv) that are destroyed in that calendar year; and

(d) a certification that the information is accurate and complete and that is dated and signed by the owner of the PCBs or products containing PCBs or by a person authorized to act on the owner's behalf.

SOR/2010-57, s. 15.

Stored PCBs or products — transfer site or destruction facility

38. The owner of an authorized facility that is a transfer site or that is authorized to destroy PCBs or products containing PCBs and who stores them at their PCB storage site, other than the owner referred to in section 37, shall prepare a report that is current to December 31 in each calendar year and that contains the following information:

- (a) the name, civic and mailing addresses, telephone number, fax number, if any, and e-mail address, if any, of the owner and of any person authorized to act on the owner's behalf;
- (b) the civic addresses of the sites where the PCBs or products containing PCBs are stored, or if there is no civic address, the location of the sites using the owner's site identification system;

exprimée en litres, la quantité de solides qui contiennent des BPC dans les produits, exprimée en kilogrammes, et la concentration de BPC dans les liquides ou les solides, exprimée en mg/kg :

- (i) stockés à son dépôt de BPC le 31 décembre,
- (ii) expédiés, au cours de l'année civile, à une installation agréée qui est un centre de transfert,
- (iii) expédiés, au cours de l'année civile, à une installation agréée qui est autorisée à les détruire,
- (iv) détruits au cours de l'année civile,

d) une attestation, datée et signée par lui ou par toute personne autorisée à agir en son nom, portant que les renseignements sont complets et exacts.

DORS/2010-57, art. 15.

38. Le propriétaire d'une installation agréée qui est un centre de transfert ou qui est autorisée à détruire des BPC et des produits qui en contiennent, autre que le propriétaire visé à l'article 37, et qui les stocke à son dépôt de BPC est tenu de préparer un rapport, au 31 décembre de chaque année civile durant laquelle il les transforme ou les détruit, comportant les renseignements suivants :

- a) ses nom, adresses municipale et postale, numéro de téléphone et, le cas échéant, numéro de télécopieur et adresse électronique, ainsi que ceux de toute personne autorisée à agir en son nom;
- b) l'adresse municipale des dépôts où sont stockés les BPC et les produits ou, à défaut, l'endroit où ils se trouvent

BPC ou produits stockés — Centre de transfert ou de destruction

(c) the quantity of liquids containing PCBs in the products, expressed in litres, or the quantity of solids containing PCBs in the products, expressed in kilograms, and the concentration of the PCBs in the liquids and the solids, expressed in mg/kg

- (i) that are stored on December 31 at the owner's PCB storage site,
- (ii) that are sent, in that calendar year, to an authorized facility that is a transfer site,
- (iii) that are sent, in that calendar year, to an authorized facility that is authorized to destroy them, or
- (iv) that are destroyed in that calendar year; and

(d) a certification that the information is accurate and complete and that is dated and signed by the owner of the authorized facility or by a person authorized to act on the owner's behalf.

d'après le système d'identification de site du propriétaire;

c) la quantité de liquides qui contiennent des BPC dans les produits, exprimée en litres, la quantité de solides qui contiennent des BPC dans les produits, exprimée en kilogrammes, et la concentration de BPC dans les liquides ou les solides, exprimée en mg/kg :

- (i) stockés à son dépôt de BPC le 31 décembre,
- (ii) expédiés, au cours de l'année civile, à une installation agréée qui est un centre de transfert,
- (iii) expédiés, au cours de l'année civile, à une installation agréée qui est autorisée à les détruire,
- (iv) détruits au cours de l'année civile,

d) une attestation, datée et signée par lui ou par toute personne autorisée à agir en son nom, portant que les renseignements sont complets et exacts.

Date of submission of report

39. (1) The person who is required to prepare a report in accordance with subsection 33(1), (2) or (4) or with any of sections 34 to 38 shall submit it to the Minister on or before March 31 of the calendar year following the calendar year for which the report is made.

Report made under subsection 33(3)

(2) The person who is required to prepare a report in accordance with subsection 33(3) shall submit it to the Minister

(a) on or before March 31, 2010 for reports that are current to December 31 of the year that these Regulations come into force up to the year 2009;

Date de présentation des rapports

39. (1) La personne qui est tenue de préparer tout rapport visé aux paragraphes 33(1), (2) ou (4) ou à l'un des articles 34 à 38 le présente au ministre au plus tard le 31 mars de l'année civile qui suit celle pour laquelle il est établi.

Rapport visé au paragraphe 33(3)

(2) Celle qui est tenue de préparer le rapport visé au paragraphe 33(3) le présente au ministre :

a) au plus tard le 31 mars 2010, s'il porte sur toute année civile suivant l'entrée en vigueur du présent règlement jusqu'à l'année 2009;

(b) on or before March 31, 2014 for reports that are current to December 31 of each of the years 2010 to 2013;

(c) on or before March 31, 2018 for reports that are current to December 31 of each of the years 2014 to 2017;

(d) on or before March 31, 2022 for reports that are current to December 31 of each of the years 2018 to 2021;

(e) on or before March 31, 2026 for reports that are current to December 31 of each of the years 2022 to 2025;

(f) on or before March 31, 2027 for reports that are current to December 31 of the year 2026; and

(g) on or before March 31, 2030 for reports that are current to December 31 of each of the years 2027 to 2029.

b) au plus tard le 31 mars 2014, s'il porte sur l'une ou l'autre des années 2010 à 2013;

c) au plus tard le 31 mars 2018, s'il porte sur l'une ou l'autre des années 2014 à 2017;

d) au plus tard le 31 mars 2022, s'il porte sur l'une ou l'autre des années 2018 à 2021;

e) au plus tard le 31 mars 2026, s'il porte sur l'une ou l'autre des années 2022 à 2025;

f) au plus tard le 31 mars 2027, s'il porte sur l'année 2026;

g) au plus tard le 31 mars 2030, s'il porte sur l'une ou l'autre des années 2027 à 2029.

DORS/2010-57, art. 16(F); DORS/2014-75, art. 8.

SOR/2010-57, s. 16(F); SOR/2014-75, s. 8.

Release into the environment

40. (1) For the purposes of paragraph 95(1)(a) of the Act, where there occurs or is a likelihood of a release into the environment of PCBs in contravention of section 5, the person who is designated to be provided with a written report is the Regional Director, Environmental Enforcement Division, Enforcement Branch of the Department of the Environment in the region where the release occurs or is likely to occur.

40. (1) Pour l'application de l'alinéa 95(1)a) de la Loi, en cas de rejet dans l'environnement — effectif ou probable — de BPC en violation de l'article 5, la personne désignée pour recevoir le rapport écrit est le directeur régional, Division de l'application de la loi en environnement, Direction générale de l'application de la loi du ministère de l'Environnement, dans la région où a lieu le rejet — effectif ou probable.

Rejets dans l'environnement

Contents

(2) The report shall include the following information:

(a) the name, civic and mailing addresses and telephone number of the person who owns or has the charge, management or control of the PCBs that are released into the environment;

(b) the date, time and location of the release;

(2) Le rapport comporte les renseignements suivants :

a) les nom, adresses municipale et postale et numéro de téléphone de la personne qui a toute autorité sur les BPC qui ont été rejetés dans l'environnement ou qui en est propriétaire;

b) les date, heure et lieu du rejet;

c) une description de la source du rejet;

Contenu

(c) a description of the source of the release; and

(d) the quantity of liquids containing PCBs released, expressed in litres, the quantity of solids containing PCBs released, expressed in kilograms, and the concentration of PCBs in the liquids and the solids that are released, expressed in mg/kg.

SOR/2010-57, s. 17.

Retention

41. Any person who is required to submit a report under these Regulations shall keep a copy of the report at their principal place of business in Canada for at least five years after the day on which the report is submitted.

Method of submission

42. Each report referred to in sections 33 to 38 shall be submitted electronically in the format provided by the Department of the Environment, but the report shall be submitted in writing if

- (a) no such format is provided; or
- (b) it is, owing to circumstances beyond the control of the person required to submit the report, impracticable to submit the report electronically in the format provided.

RECORD KEEPING

[SOR/2011-301, s. 6]

Records for permitted activities

43. The following persons shall maintain records containing information and documents that demonstrate that they manufacture, process, use, sell, offer for sale, store, import or export PCBs or products containing PCBs in accordance with the Act and these Regulations:

- (a) the owner of PCBs or products containing PCBs;

d) la quantité de liquides qui contiennent des BPC rejetés, exprimée en litres, la quantité de solides qui contiennent des BPC rejetés, exprimée en kilogrammes, et la concentration de BPC dans les liquides ou les solides rejetés, exprimée en mg/kg.

DORS/2010-57, art. 17.

Conservation

41. Toute personne qui est tenue de présenter un rapport en application du présent règlement en conserve une copie à son établissement principal au Canada pendant au moins cinq ans après la date de sa présentation.

Méthode de présentation

42. Les rapports visés aux articles 33 à 38 sont présentés sous forme électronique selon le modèle établi par le ministère de l'Environnement. Ils sont toutefois présentés par écrit dans les cas suivants :

- a) aucun modèle n'a été établi par le ministère;
- b) il est pratiquement impossible, pour des raisons indépendantes de la volonté de la personne tenue de les présenter, de le faire sous forme électronique selon le modèle établi.

TENUE DE REGISTRES

[DORS/2011-301, art. 6]

Registres des activités permises

43. Les personnes ci-après conservent dans un registre les renseignements et les documents établissant que des BPC ou des produits qui en contiennent ont été fabriqués, transformés, utilisés, mis en vente, vendus, stockés, importés ou exportés conformément à la Loi et au présent règlement :

(b) the person who is engaged in any of these activities; and

(c) the owner or operator of a PCB storage site.

SOR/2011-301, s. 7.

a) le propriétaire des BPC ou des produits;

b) la personne qui exerce l'activité;

c) le propriétaire ou l'exploitant du dépôt de BPC.

DORS/2011-301, art. 7.

Inspection record

44. (1) The owner or operator of a PCB storage site shall maintain a record of all inspections conducted at the PCB storage site under paragraph 27(a)

(a) listing all items that are inspected;

(b) describing any deficiency found;

(c) setting out the measures taken to remedy the deficiency; and

(d) specifying the dates of the inspections and the names of the inspectors.

44. (1) Le propriétaire ou l'exploitant d'un dépôt de BPC tient un registre de toutes les inspections effectuées au dépôt de BPC en application de l'alinéa 27a), lequel fait état :

a) de tous les points inspectés;

b) de toutes les lacunes relevées;

c) des mesures prises pour y remédier;

d) de la date de l'inspection et du nom de l'inspecteur.

Registres d'inspections

Owner of equipment — extension

(2) The owner of equipment for which an extension of the end-of-use date is applied under section 17 shall maintain a record of all inspections conducted on the equipment that contains the information set out in paragraphs (1)(a) to (d).

SOR/2010-57, s. 18(F).

(2) Le propriétaire d'une pièce d'équipement dont l'utilisation fait l'objet d'une prolongation en vertu de l'article 17 tient un registre de toutes les inspections de la pièce d'équipement qui ont été effectuées, lequel fait état des renseignements prévus aux alinéas (1)a) à d).

DORS/2010-57, art. 18(F).

Propriétaire d'une pièce d'équipement — prolongation

Retention of records

45. The person who is required to maintain a record under sections 43 and 44 shall retain it at their principal place of business in Canada or at the place where they conduct the activity for at least five years

(a) after the destruction of the PCBs or the products containing PCBs that are the subject of the record, in the case of the owner of PCBs or products containing PCBs or the owner or operator of the PCB storage site where the PCBs or products containing PCBs are stored; or

(b) after the completion of an activity referred to in section 43, in the case of

45. Toute personne qui a l'obligation de tenir un registre en application des articles 43 et 44 le conserve à son établissement principal au Canada ou à l'établissement où l'activité est exercée pendant au moins cinq ans après :

a) dans le cas du propriétaire de BPC ou de produits qui en contiennent ou du propriétaire ou de l'exploitant d'un dépôt de BPC où sont stockés des BPC ou des produits qui en contiennent, la date de destruction des BPC ou des produits qui en contiennent décrits dans le registre;

Conservation des registres

the person who is engaged in that activity.

SOR/2011-301, s. 8(F).

b) dans le cas de la personne qui exerce une activité visée à l'article 43, la date de la fin de l'activité.

DORS/2011-301, art. 8(F).

PART 5

REPEALS AND COMING INTO FORCE

REPEALS

46. [Repeal]

47. [Repeal]

COMING INTO FORCE

48. These Regulations come into force on the day on which they are registered.

Coming into force

PARTIE 5

ABROGATIONS ET ENTRÉE EN VIGUEUR

ABROGATION

46. [Abrogation]

47. [Abrogation]

ENTRÉE EN VIGUEUR

48. Le présent règlement entre en vigueur à la date de son enregistrement.

Entrée en vigueur



Figure 1: Site Layout and Location of Spill Kits

Appendix A

Spill Locations



Image retrieved from Department of Municipal and Community Affairs 2015-07-23

PAULATUK

SEWAGE AND SOLID WASTE
SITE ASSESSMENT

STORAGE AND
SPILL KIT LOCATIONS



BUILDING FOOTPRINT

ROADS

AIRSTRIP

DRAINAGE PATHS

POTENTIAL SPILL LOCATIONS

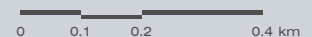
WETLAND AREA



MAP DRAWING INFORMATION:
DATA PROVIDED BY GNWT AND
DILLON CONSULTING

MAP PROJECTION: NAD 1983 UTM Zone 10N

SCALE 1:12,500



PROJECT: 202937

DATE: 2020-07-16

Appendix B

Immediately Reportable Spill Quantities

Substance	Reportable Quantity	TDG Class
Explosives	Any amount	1.0
Compressed gas (toxic/corrosive)		2.3/2.4
Infectious substances		6.2
Sewage and Wastewater (unless otherwise authorized)		6.2
Radioactive materials		7.0
Unknown substance		None
Compressed gas (Flammable)	Any amount of gas from containers with a capacity greater than 100L	2.1
Compressed gas (Non-corrosive, non-flammable)		2.2
Flammable liquid	≥100 L	3.1/3.2/3.3
Flammable solid	≥ 25 kg	4.1
Substances liable to spontaneous combustion		4.2
Water reactant substances		4.3
Oxidizing substances	≥ 50 L or 50 kg	5.1
Organic peroxides	≥1 L or 1 kg	5.2
Environmentally hazardous substances intended for disposal		9.0
Toxic substances	≥ 5 L or 5 kg	6.1
Corrosive substances	Miscellaneous products, substances or organisms	8.0
Miscellaneous products, substances or organisms		9.0
PCB mixtures of 5 or more ppm	≥ 0.5 L or 0.5 kg	9.0
Other contaminants--for example, crude oil, drilling fluid, produced water, waste or spent chemicals, used or waste oil, vehicle fluids, wastewater.	≥ 100 L or 100 kg	None
Sour natural gas (i.e., contains H ₂ S)	Uncontrolled release or sustained flow of 10 minutes or more	None
Sweet natural gas		
Flammable liquid	≥ 20 L	3.1/3.2/3.3
Vehicle fluid	When released on a frozen water body that is being used as a working surface	None
Reported releases or potential releases of any size that:	Any amount	None
1. are near or in an open water body;		

Substance	Reportable Quantity	TDG Class
2. are near or in a designated sensitive environment or habitat; 3. Pose an imminent threat to human health or safety; or 4. Pose an imminent threat to a listed species at risk or its critical habitat		

Source: Department of Environment and Natural Resources, Government of Northwest Territories²

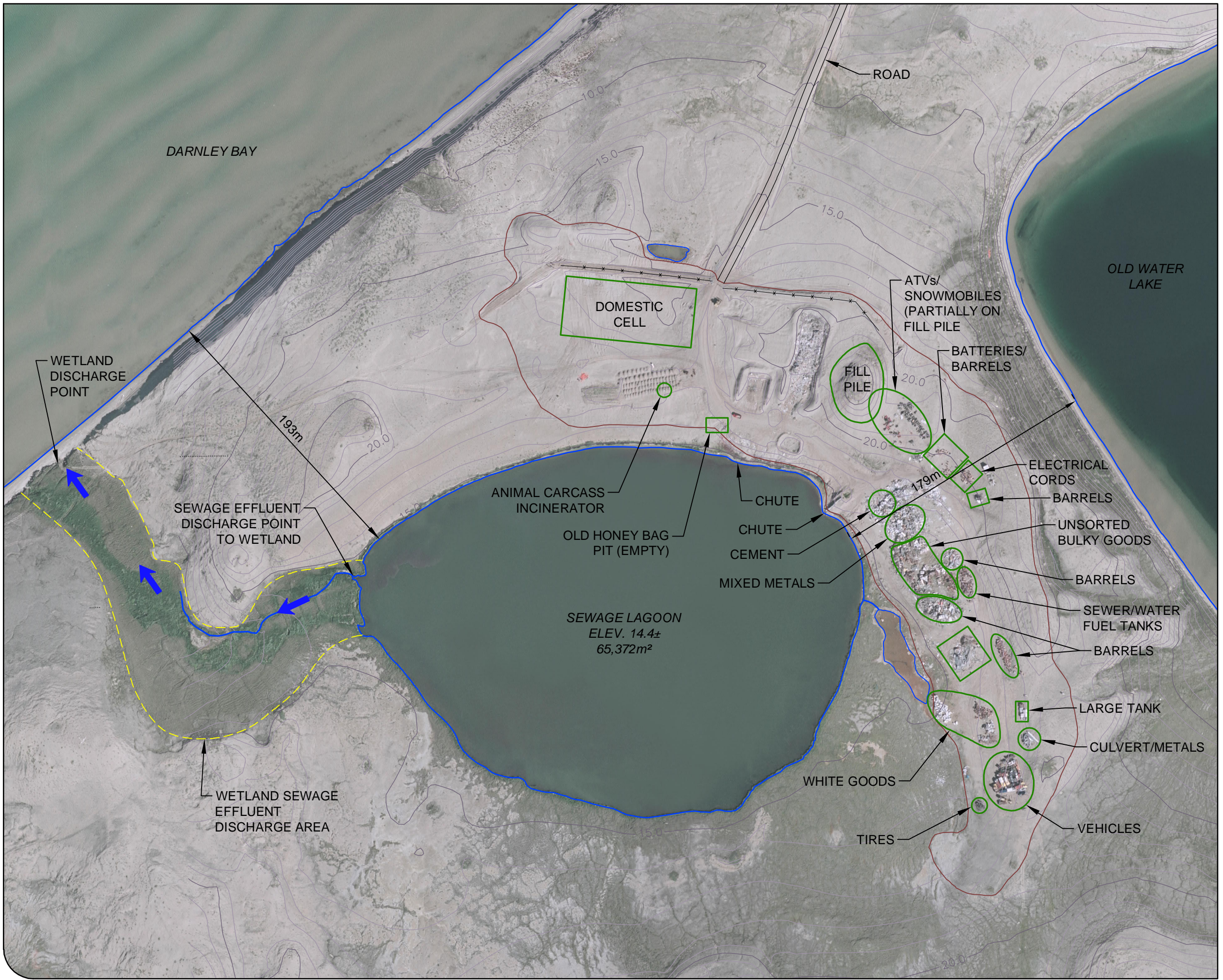
Notes:

- L: Litre
- kg: kilogram
- PCB: polychlorinated biphenyls
- ppm: parts per million

² Retrieved August 30, 2017 from <http://www.enr.gov.nt.ca/en/services/spills/reporting-spills>.

Appendix A

Sewage and Solid Waste Site Plan

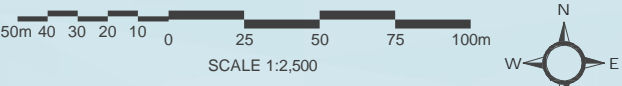


GOVERNMENT OF THE NWT
PAULATUK WATER LICENCE RENEWAL



SEWAGE TREATMENT SYSTEM AND
SOLID WASTE DISPOSAL AREA
Figure 2

- SOLID WASTE FACILITY
- ROADS
- FENCE
- DRAINAGE PATHS
- WETLAND AREA
- LANDFILL FEATURES
- ← FLOW DIRECTION



MAP/DRAWING INFORMATION
2009 Cadastral information supplied by Commissioners Land Administration, ATLAS online. Paulatuk (2007) photo came from the Department of Municipal and Community Affairs. Locations and Features are Approximate.

CREATED BY: CLB
CHECKED BY: TLR
MAP PROJECTION: NAD83 UTM Zone 10N

File Location:
c:\project\working directory\projects 2020\5011r\dms31306\202937 figs .dwg
June, 03, 2020 3:12 PM



PROJECT: 202937
STATUS: Issued for Review
DATE: June 2020